

Asona Ultratone™

Perforated GIB® Plasterboard Acoustic Lining

Technical Installation Manual



asona



Contents

Section	Description	Page
1.0	General information	2
2.0	Technical Installation Specifications	3
3.0	Components and Ancillary Products	4-5
4.0	Installation	6
4.1	Installation – standard, suspended ceilings	6-8
4.2	Installation – standard, direct fixed ceilings	9
4.3	Installation - panel attachment, fixing centres	10
5.0	Joint finishing	11
6.0	Painting	12
7.0	Tools	12

Asona Ultratone™

Perforated Plasterboard Acoustic Lining

Technical Installation Manual



ASONA

1.0 General Information

Description

Asona Ultratone™ is a perforated GIB® plasterboard panel lining for acoustic ceilings and walls. Made in NZ, Ultratone™ is manufactured in a range of perforation patterns and open areas to meet acoustic and aesthetic requirements. Panels are screw fixed and flush stopped to level 4 and painted on site for a monolithic appearance.

Asona Ultratone™ is a durable lining for control of unwanted noise reverberation in residential and commercial construction; open plan living and office spaces, meeting rooms, receptions, hallways, hotels, healthcare, retirement facilities, auditoria, libraries, halls, malls etc.

Application.

Asona Ultratone™ panels are designed for ceiling lining or high wall application (ie above 2.0m). Installation options include:

- suspended steel systems (Rondo KEY-LOCK® or Rondo Xpress® Drywall Grid)
- direct fixed Rondo steel battens on steel brackets
- direct fixed Rondo steel battens
- kiln dried timber battens

NOTE: Steel systems are the preferred method to provide a more stable structure to minimise any joint cracking.

Composition.

Ultratone™ panels are manufactured in NZ from GIB® plasterboard with acoustic tissue backing.

General.

The installation details and information contained within this Asona Ultratone™ Technical Installation Manual provides an extensive range of construction methods that can be adapted to suit individual projects.

Disclaimer

"Asona Ultratone™ Panels and components as described must be used and installed in accordance with the installation instructions detailed within this guide. Use of any other installation methods, materials or components may result in component failure and void the warranty of the product and system"

Asona Ltd

P.O Box 96-241
Balmoral,
Auckland, New Zealand
Sales: 09 525 6575
Email: info@asona.co.nz
Web: www.asona.co.nz

Factory:
Building 12-16, 7 Cain Road,
Penrose, Auckland 1061,
New Zealand
Tel: (09) 525 6575

ISO 9001:2015 Registered Firm No. NZ1014
© 2023 Copyright ASONA Ltd. Triton and Ultratone are trademarks of Asona.
KEY-LOCK and Xpress are trademarks of Rondo Building Services Pty Ltd.
GIB is a registered trademark of Fletcher Building Holdings Ltd
All dimensions are nominal. We reserve the right to change specifications without notice.
Ref. Ultratone IM-23-01



Asona Ultratone™

Perforated Plasterboard Acoustic Lining

Technical Installation Manual



asona

2.0 Technical Installation Specification

Back Loading:

Uniform distributed load of fixtures, fittings and insulation is not to exceed 2kg/m². Lighting, A/C grills, speakers etc, shall not exceed 1.5kg. Greater weights and any point loads shall be independently supported.

Installed Conditions:

Max 90% R/H at 30°C.

NZ Building Code:

Clause B2—durability, 15 years.

Maintenance:

Clean with vacuum, soft brush, or damp cloth once painted.

Weight: (nominal)

Non perforated board - 8.5 kg/m²,

10% open area - 7.8-8 kg/m²,

20% open area - 6.9-7.2 kg/m²

Handling & Storage

- Asona Ultratone™ panels should be handled as a “finishing” material.
- Do not drag panels when lifting from pallet.
- Handle with care, on edge, not flat, avoid bending and edge damage.
- Store Ultratone™ panels on a flat dry surface clear of the floor with adequate support to prevent bending, and protect edges.
- Keep dry, clean, and free from dust and debris, and protected from weather.
- When storing onsite protect the panels from possible damage by other trades.

Limitations of Use

- The Ultratone™ panel is not designed for use in external applications.
- Not for use with negative air return plenums, in direct contact with moisture, in extreme humidity conditions, or temperatures in excess of 52° C for prolonged periods.
- Where Ultratone™ panels are to be attached to ceiling or wall battens, they are not to be used as a structural bracing element. (ceiling diaphragm)
- Panels are not to be used by sub-trades to support other services or equipment.
- To maintain acoustic performance do not spray paint.
- Damaged or cracked product is not to be installed.
- Ultratone™ is not to be used or substituted in Fire Rated ceiling or wall systems.

Installation

- The installation of Asona Ultratone™ panels can be carried out by tradespersons or suspended ceiling installers who are competent in installing plasterboard panels.
- Shall not commence until the building is water tight and dry.
- Fully support panels when positioning and fixing to framing. The use of mechanical lifting machines is recommended for ceilings.

Seismic Bracing

- If the panels are attached to a suspended ceiling, then the weight of the panels shall be included in the ceiling seismic design calculations. Install bracing as required by the seismic design. For preliminary advice, please contact Asona Ltd.

Do's

- Use the specified components as detailed in this manual.
- Ensure panels are aligned correctly to match perforation pattern clusters.
- Install control joints at maximum spacing of 12m and at junctions.

Don'ts

- Do not install Asona Ultratone™ panels until the building is watertight.
- Adhesives are not to be used to attach Ultratone™ perforated panels.

Asona Ultratone™

Perforated Plasterboard Acoustic Lining

Technical Installation Manual



ASONA

3.0 Components & Ancillary Products

<p>Ultratone Panel 1200 x 2400 x 13mm (W1L1 perforation cluster shown)</p>	
<p>Rondo KEY-LOCK® Furring Channel #155 - 48mm</p>	
<p>Rondo KEY-LOCK® Top Cross Rail (TCR) #127</p>	
<p>Rondo KEY-LOCK® Joiner Clip #159 #155 Furring Channel to TCR</p>	
<p>Rondo KEY-LOCK® Wall Track #140</p>	
<p>Rondo KEY-LOCK® Direct Fix Clip #156 For #155 Furring Channel</p>	
<p>Rondo ScrewFix® Furring Channel #F37</p>	
<p>Rondo ScrewFix® Direct Fix Clips #FDFS—(short) #FDFL—(long) For #F37 Furring Channel</p>	

For full range of accessory options refer to Rondo KEY-LOCK® System manual

Asona Ultratone™





Perforated Plasterboard Acoustic Lining

Technical Installation Manual

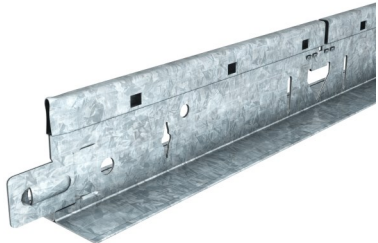

asona

3.0 Components & Ancillary Products, cont.

<p>Rondo Wall Trim #553—35mm x 35mm #XD5—40mm x 40mm</p>	
<p>Rondo Xpress® Drywall Grid #XD1/XD1H—Main Tee, 3600mm</p>	
<p>Rondo Xpress® Drywall Grid #XD2—Cross Tee, 1200mm & 600mm</p>	
<p>Rondo Xpress® Drywall Grid #XD6—Wall Trim Channel, 3600mm x 40 x 38 x 19mm</p>	
<p>Rondo Xpress® Drywall Grid #DXCL—Suspension Clip</p>	
<p>Suspension HW-Ø2.5 Hanger Wire, 3600mm #DXDF-Direct Fix Strap</p>	

For full range of accessory options refer to Rondo Xpress® Drywall Grid System manual

Asona Ultratone™

Perforated Plasterboard Acoustic Lining

Technical Installation Manual



asona

4.0 Installation

4.1 Standard Method— Suspended Ceilings

The preferred installation method is to mount Ultratone™ panels onto steel framing. Recommended systems are Rondo KEY-LOCK®, Rondo Xpress® Drywall Grid, Rondo ScrewFix®. These are typically suspended but there are direct-fix options. See 4.2

Installation shall not commence until the building is watertight and dry.

Installation Overview:

Set out panel panels carefully, as layout and panel fastening centres will dictate framing positioning.

- TCR/Main Tee framing shall be 1200mm centres maximum
- Suspension 1200mm maximum
- Furring channel/battens/cross tees at 600mm maximum.

Additional products attached to the ceiling may require reducing the framing centres to take the additional weight. Refer to Rondo's Design manuals for appropriate spacings.

Framing and Suspension maximum centres

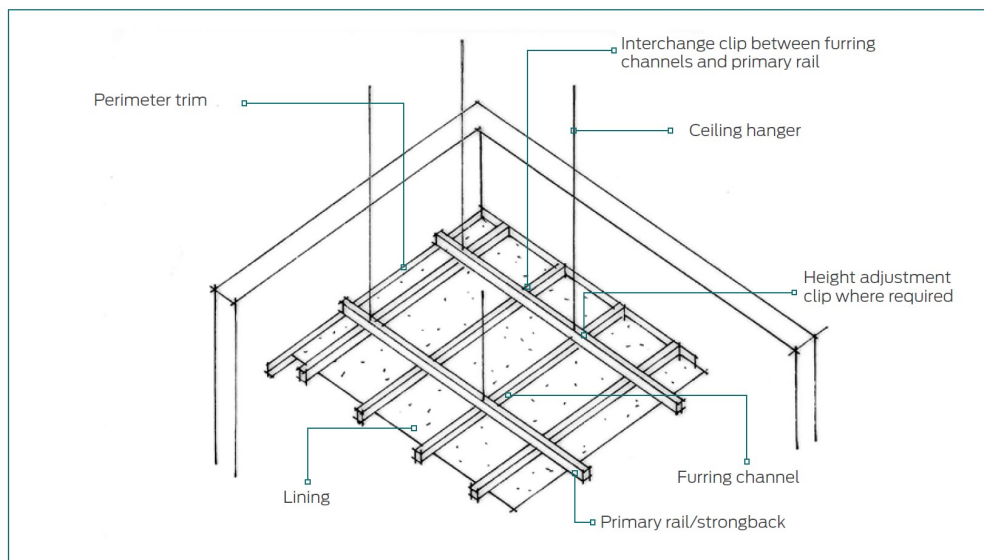
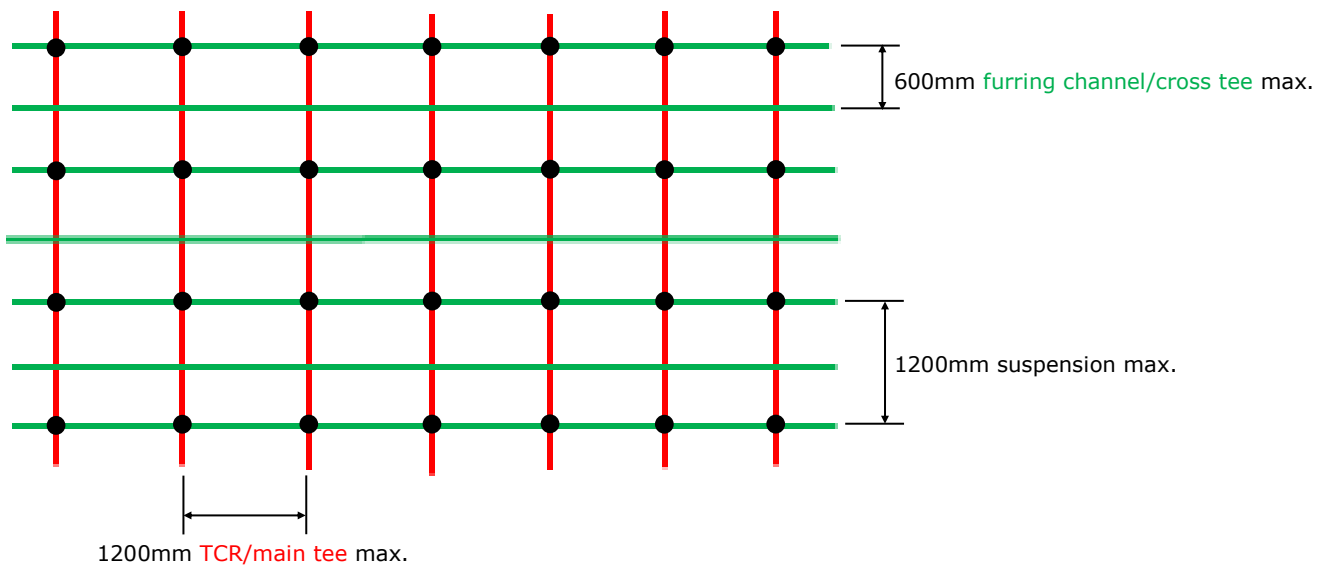

Asona Ultratone™

Perforated Plasterboard Acoustic Lining

Technical Installation Manual



asona

4.0 Installation

4.1 Standard Method— Suspended Ceilings

The preferred installation method is to mount Ultratone™ panels onto steel framing. Recommended systems are Rondo KEY-LOCK®, Rondo Xpress® Drywall Grid, Rondo ScrewFix®. These are typically suspended but there are direct-fix options. See 4.2

Installation shall not commence until the building is watertight and dry.

Installation Overview:

Suspended ceiling framing options

Rondo KEY-LOCK®

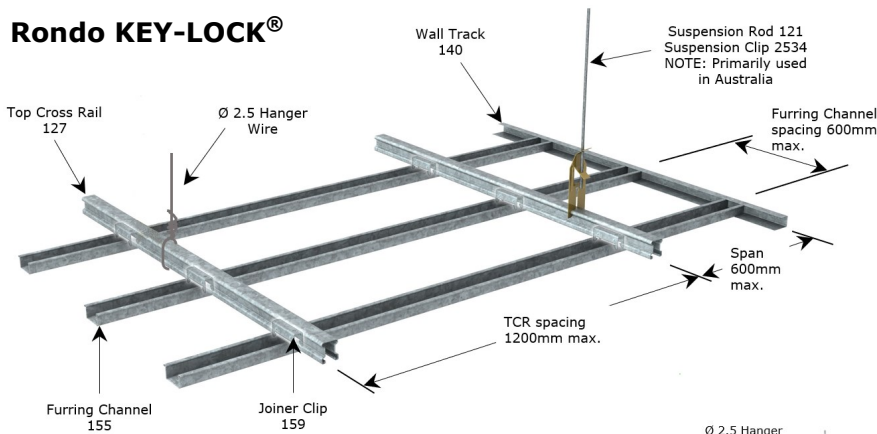

Rondo Xpress®

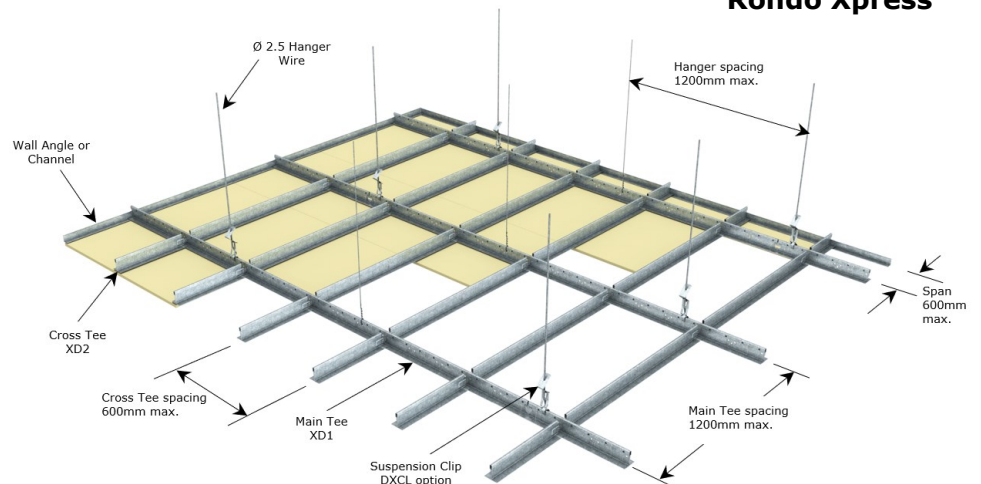

Rondo ScrewFix®

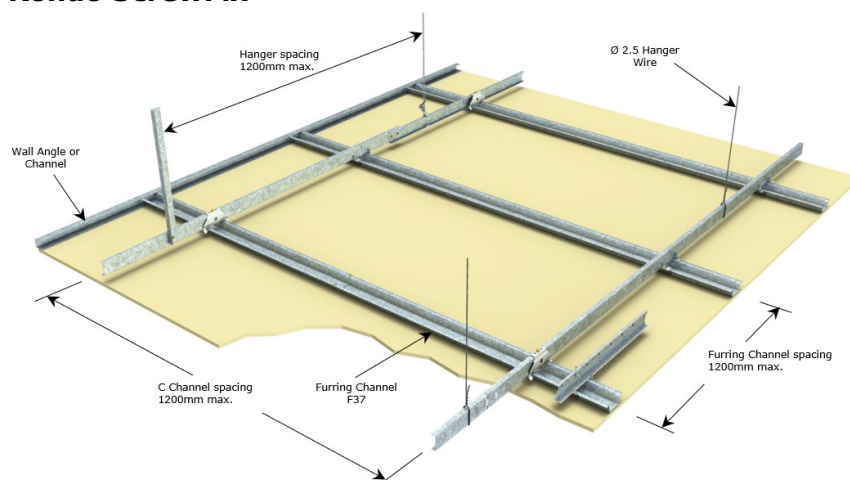

Asona Ultratone™

Perforated Plasterboard Acoustic Lining

Technical Installation Manual



asona

Ceiling Layout

- Divide the ceiling panel layout from the centre of the room to ensure a uniform border and pattern, or as detailed on the architectural RCP.
- Panels are installed perpendicular to furring channel or cross tees.
- Position short ends to finish on furring channel or cross tees.
- Ensure perforations of adjacent panels align.

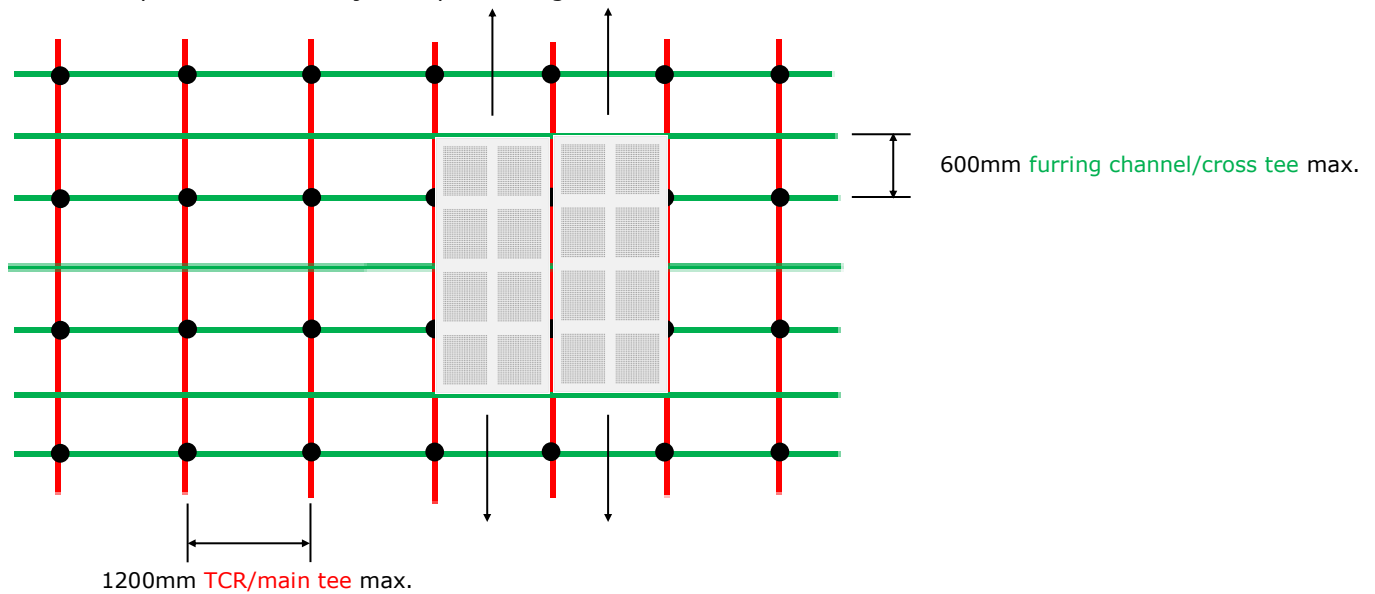

Alternative Ceiling Layout with Plain Border

- Position the ceiling panel layout from the centre of the room to the last full panel. The balance to the wall can use standard 13mm non-perforated plasterboard to provide a seamless border.
- Panels are installed perpendicular to furring channel or cross tees.
- Position short ends to finish on furring channel or cross tees.

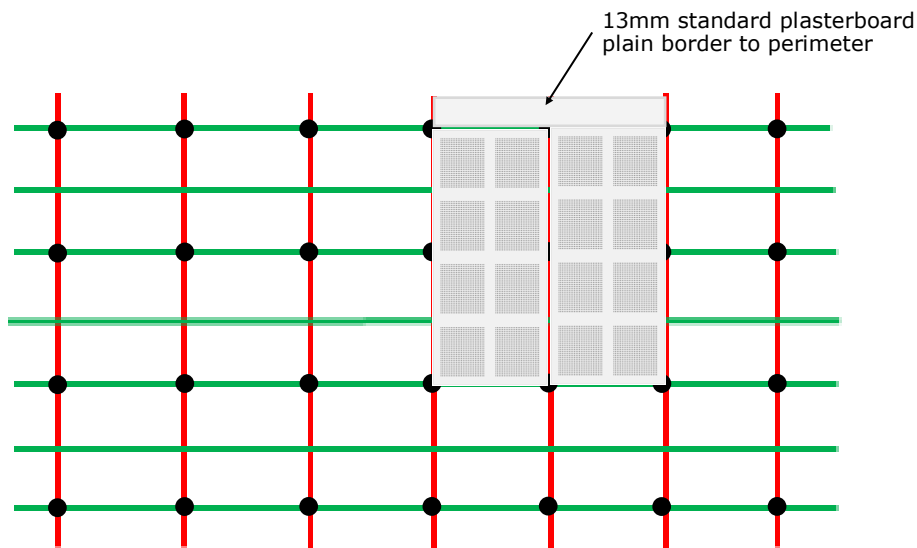

Asona Ultratone™

Perforated Plasterboard Acoustic Lining

Technical Installation Manual



asona

4.2 Standard Method— Direct Fixed Ceilings

Installation shall not commence until the building is watertight and dry.

Installation Overview:

Where the installation of Ultratone™ panels is to be direct fixed to the building structure (floors/joist/purlins) is required, set out the steel furring channel/battens to suit the panel layout, 600mm centres maximum.

If attaching to timber joists of a trafficable floor, it is recommended to use direct fix brackets to assist isolation from potential floor deflection, which can result in cracking joints.

Direct fix brackets shall be used at 1200mm centres maximum.

Rondo Furring Channel/Batten

Rondo KEY-LOCK®

- #155 Furring Channel/Batten
- #156 Direct Fix Bracket

Rondo ScrewFix®

- #F37 Furring Channel/Batten
- #FDFS Direct Fix Bracket (short)
- #FDFL Direct Fix Bracket (long)



Ceiling Layout

- Divide the ceiling panel layout from the centre of the room to ensure a uniform border and pattern, or as detailed on the architectural RCP.
- Panels are installed perpendicular to furring channel/battens.
- Position short ends to finish on furring channel/batten.
- Ensure perforations of adjacent panels align.

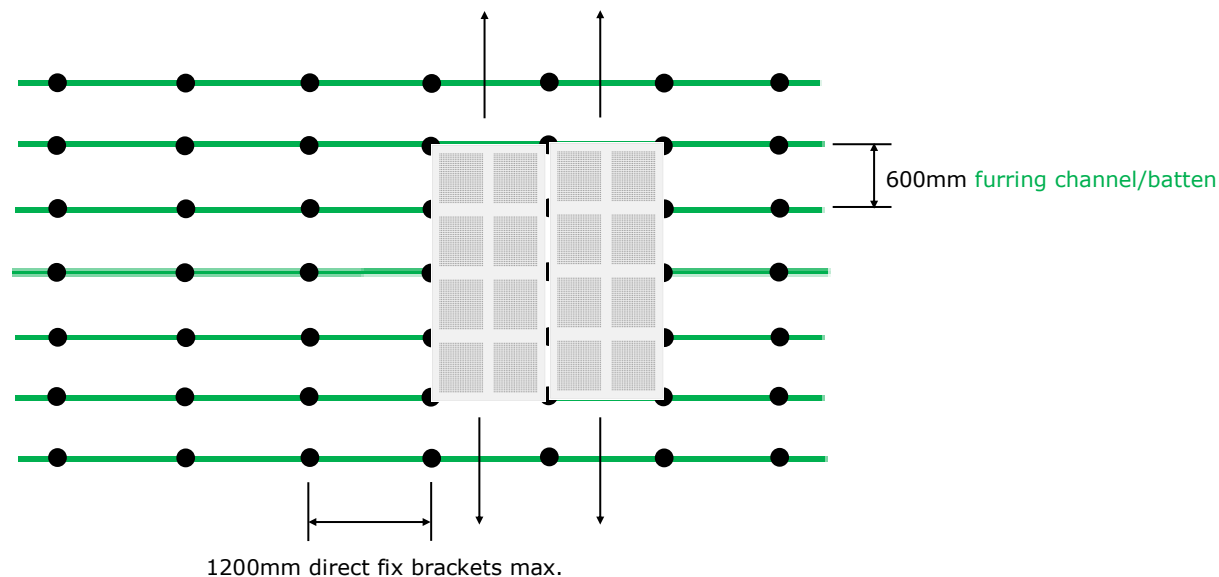

Asona Ultratone™

Perforated Plasterboard Acoustic Lining

Technical Installation Manual



asona

4.3 Panel Attachment and Fixing Centres

Installation shall not commence until the building is watertight and dry.

Panel Attachment

- Fully support Ultratone™ panels when positioning and fixing to framing. The use of mechanical lifting machines is recommended for ceilings.
- Fix off to the installed steel framing using 6g x 25mm minimum bugle head drywall screws.
- Install control joints at 12m maximum spacing and at junctions of hallways and large rooms.



Fixing Centres:

- Use screws at a maximum of 200mm centres at panel ends and edge joints and 300mm in the field. Do not use adhesives.
- Screws are not to be closer than 12mm from sheet ends or edges.
- Where possible, ensure that the furring channels or tees line up with the clear spaces between perforations. If they cannot be aligned with clear spaces, ensure fasteners are placed centrally between and no closer than 8mm to the edge of perforations.

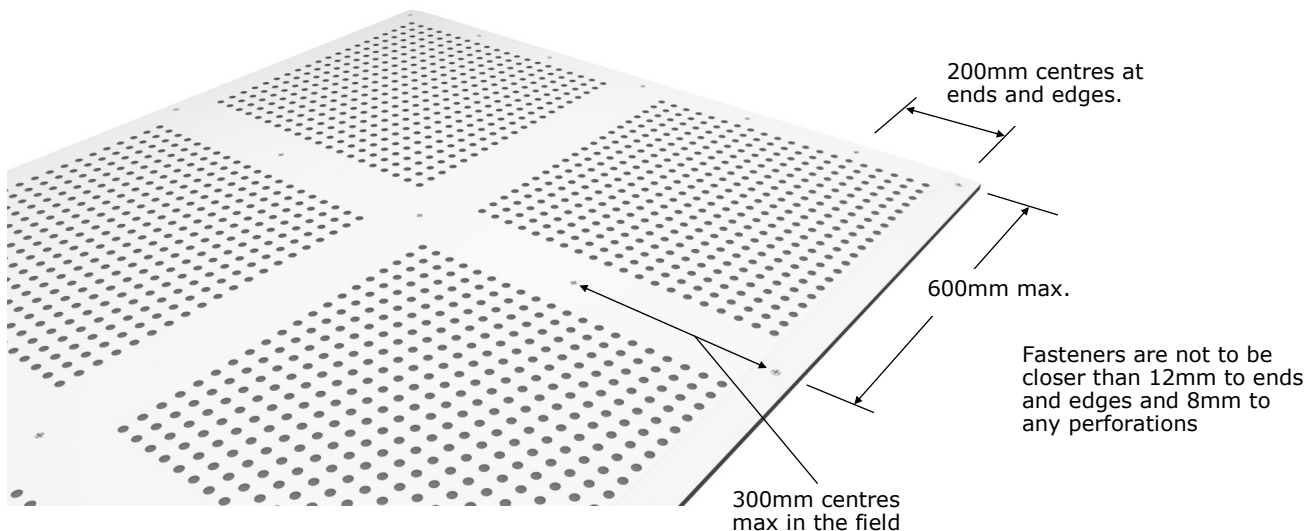

Asona Ultratone™

Perforated Plasterboard Acoustic Lining

Technical Installation Manual



asona

5.0 Joint Finishing

A low tack, thin masking tape can be used to mask perforations during stopping to minimise accidental filling of the perforations. This is easiest achieved while the panel is on the floor prior to installation. Fill joints with a 3 coat system and paper reinforcing tape, taking care not to fill perforations, and remove immediately any compound from holes. Leave a gap between the base compound and edge of perforations to ensure the final coat of air dry compound can be sanded to a feathered edge. Sand any ridges after the joints have dried. Remove masking tape once joints have been finished taking care not to tear the plasterboard paper around holes.

Tapered Joints

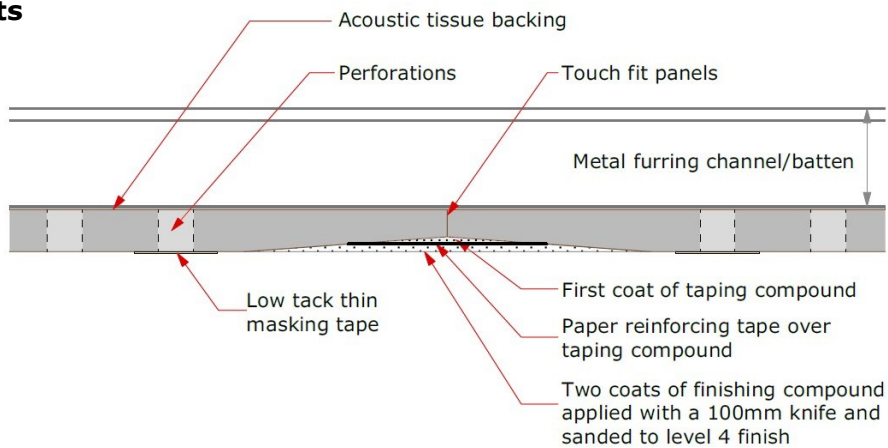

Butt Joints

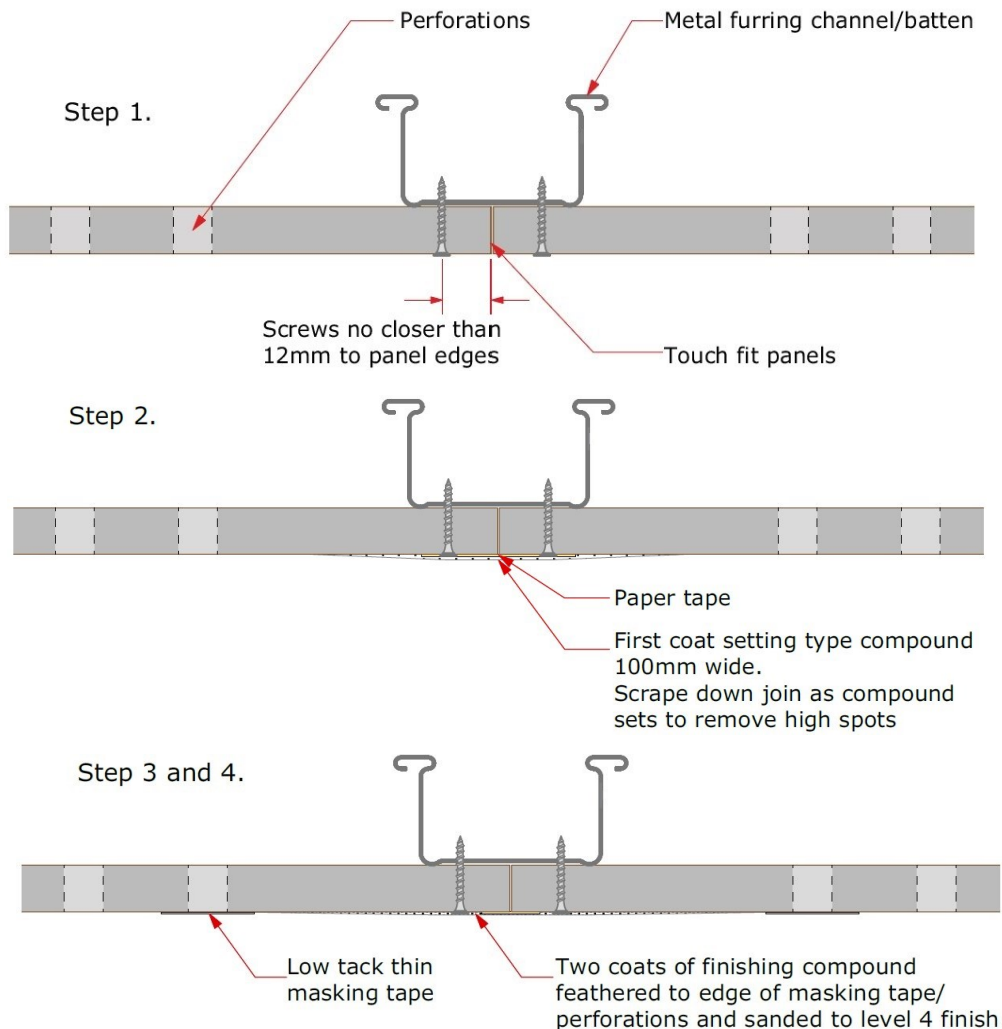

Asona Ultratone™

Perforated Plasterboard Acoustic Lining

Technical Installation Manual



asona

6.0 Painting Ultratone™ Panels

- Make sure the compound is completely dry and the surface smooth and free from dust.
- Apply paint system with a fine nap roller and ensure that perforation holes are not filled and the backing fabric is not clogged.
- Make sure the paint is not too thick and avoid applying too much paint at a time.
- Apply paint system to manufacturers instructions to ensure the best quality finish.

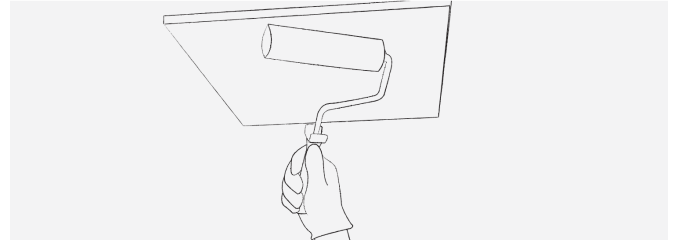

Note: Paint must not be spray applied as this will reduce acoustics.

7.0 Tools

Box Cutter, Knife, Utility Knife.	
Tape Measure	
Tee Square	