

triton pool panel vg™



High Sound Absorbing Ceiling Panel for Swimming Pools Technical Installation Manual



triton pool panel vg™

High Sound Absorbing Ceiling Panel for Swimming Pools Technical Installation Manual

Triton Pool Panel VG™ is a proprietary high sound absorbing acoustic panel designed specifically for swimming pool ceilings and high-up wall applications. The panels have a 50mm acoustic core with the face & edge wrapped in Sonatex™ glass mat composite finish which has been treated with a water repellent coating. The panels are also back laminated with a METPET foil vapour barrier.

Section	Description	Page
1.0	General information	3
2.0	Technical Installation Specifications	4
3.0	Components and Ancillary Products	5-6
4.0	Installation	7
4.1	Installation – standard, direct fixed	7-10
4.2	Installation– alternative, suspended	11-16
4.3	Installation of services and penetrations	17
4.4	Access panels	17
5.0	Cutting	18-25
6.0	Tools	26-27



ISO 9001:2015 Registered Firm No. NZ1014

© 2026 Copyright ASONA Ltd Asona, Triton, Pool Panel VG, are trade marks of Asona Ltd,

*All dimensions are nominal. We reserve the right to change specifications.
Ref. Pool Panel VG IM-26.06

Asona Ltd. Office & Factory
6 Mahunga Drive, Māngere
Bridge, Auckland 2022
New Zealand
NZBN: 9429036035175

New Zealand

T: +64(0)9 525 6575

E: info@asona.co.nz

W: www.asona.co.nz

Australia

T: 1 800 240361

E: info@asona.com.au

W: www.asona.com.au

asona

triton pool panel vg™

High Sound Absorbing Ceiling Panel for Swimming Pools

1.0 General Information

Description

Triton Pool VG™ panels are a proprietary edge wrapped 50mm acoustical panel system designed to control unwanted noise reverberation with ceilings and high level walls for indoor swimming pools.

Application

Triton Pool VG™ panels are to be mounted under insulated warm roof systems as an open system with no concealed or enclosed cavity behind the panels (minimum 50mm) for buildings with managed ventilation. The intent is to allow free movement of conditioned air to circulate around the panels which will help to reduce the risk of condensation. Install panels outside of the splash zone, free of direct contact with water.

Composition

Manufactured in NZ, from non-combustible glass fibre core, back laminated with METPET foil vapour barrier, and faced and edge wrapped in 2 ply Sonatex™ glass mat laminate with water repellent coating.

General

The installation details and information contained within this Asona Triton Pool Panel Installation Manual provides an range of construction methods that can be adapted to suit individual projects. Asona Ltd can also provide custom made components should there be a particular requirement.

Corrosion Resistance

- Asona Ltd has selected and evaluated products that are suitable for use in a swimming pool environment as well as develop methods of construction that are used with the Triton Pool Panel VG system to reduce risk of corrosion.
- Selection of metal fixing and framing components is important in indoor pool environments. Galvanic corrosion and stress fracture failure of parts has occurred overseas, and care shall be taken during installation. Aluminium and Stainless Steel may be used products in indoor swimming pool environments however joining of stainless steel to aluminium is to be avoided where possible as this type of connection may lead to galvanic corrosion and failure of the fixing.
- The use of appropriate grade stainless steel fasteners are permitted and are detailed in the components schedule however isolating the stainless-steel fastener from aluminium brackets by using plastic or rubber washers is critical to prevent galvanisation occurring causing corrosion of the components. (Refer Subframe Construction Details).
- All aluminium brackets and components shall be protected against galvanic corrosion. This can be achieved by either powder coating or anodising (Marine Grade 25 micron minimum) each component. A selection of colours of both powder coating and anodising can be provided. Typically, white or black is the standard colour for visible components as these are camouflaged in the shadowline between panels.

Disclaimer

“Swimming pool environments require materials and components to have a high resistance to corrosion. The materials and components detailed within this guide provide a high resistance to the corrosive effects of an indoor swimming pool environment.”

“Asona Triton Pool Panels VG and components as described must be used and installed in accordance with the installation instructions detailed within this guide. Use of any other installation methods, materials or components may result in component failure and void the warranty of the product and system”.



ISO 9001:2015 Registered Firm No. NZ1014

© 2026 Copyright ASONA Ltd Asona, Triton, Pool Panel VG, are trade marks of Asona Ltd,

*All dimensions are nominal. We reserve the right to change specifications.
Ref. Pool Panel VG IM-26.06

Asona Ltd. Office & Factory New Zealand Australia
6 Mahunga Drive, Māngere T: +64(0)9 525 6575 T: 1 800 240361
Bridge, Auckland 2022 E: info@asona.co.nz E: info@asona.com.au
New Zealand W: www.asona.co.nz W: www.asona.com.au
NZBN: 9429036035175

asona

triton pool panel vg™

High Sound Absorbing Ceiling Panel for Swimming Pools

2.0 Technical Installation Specification

Back loading:

Max. 1.5 kg/m², point loads shall be independently supported.

Humidity:

Max 95% R/H at 45°C. Face not designed for direct contact with water. Control humidity to prevent condensation.

NZ Building Code:

Clause B2—durability, 5 years.

Maintenance:

Clean with vacuum, soft brush, or damp cloth. Re-surfacing of soiled panels available, consult Asona.

Thermal Resistance:

R 1.47 m²°C/W

Weight:

3 kg/m²

Handling & Storage

- Handle with care, avoid bending and edge damage.
- Store Triton Pool Panels on a flat dry surface with adequate support to prevent bending.
- Keep dry, clean, and free from dust and debris.
- Pay special attention to the edges.
- When handling wear white gloves to avoid marking the panels.
- When storing onsite protect the panels from possible damage by other trades.

Limitations of Use

- The Triton Pool Panel VG is for interior use only.
- Face is not designed for direct contact with water.
- Maximum humidity/temperature 95% R/H at 45°C. It is recommended to control humidity to 70% RH maximum to prevent condensation forming on the structure.
- Back loading — Panels are not to be used by sub-trades to support other services or equipment. No overlay loads, M&E services and point loads to be independently supported. Lightweight fittings may be attached, ref Section 4.3.

Installation

- The installation of Asona Triton Pool Panels VG can be carried out by competent tradesperson or suspended ceiling installer who has received training from Asona.

Health & Safety and PPE

- Wear loose long sleeve clothing.
- Safety glasses.
- Clean gloves.
- Dust mask.
- If cutting with power tools use dust extraction.

Seismic Bracing

- Triton Pool panels are designed to be attached to the building structure, purlins, beams or battens with aluminium brackets. Bracing is generally not required.
- If the panels are attached to a suspended sub structure or a lined suspended ceiling system, then the weight of the Triton Pool panels shall be included in the seismic design calculations. Install bracing as required by the seismic design. Bracing shall be of a material type suitable for pool environments.
- For preliminary advice, please contact Asona Ltd.

Do's

- Use the specified components as detailed in this manual.
- Maintain a minimum 50mm gap between and behind panels to maintain free air movement around panels.
- Control the indoor environment to prevent condensation occurring on any building element through use of mechanical ventilation. It is recommended to control humidity to 70% RH maximum to prevent condensation forming.
- Avoid penetrations of the Pool Panel wherever possible by installing utilities between panels. Adjust panel sizes to accommodate services. Where this is not possible, penetrations through the panels must have sufficient clearance around the penetration.

Don'ts

- Do not install Asona Triton Pool Panels VG until the building is water tight.
- Do not use galvanized fasteners in a Swimming Pool environment.
- Do not combine different metals together such as Aluminium and Stainless Steel unless they are isolated from each other. Failure to isolate may result in galvanic corrosion.
- Do not install panels within the splash zone or in direct contact with water, or areas subject to, but not limited to, condensation, leaking pipes and/or ducts or steam.

ISO 9001:2015 Registered Firm No. NZ1014

© 2026 Copyright ASONA Ltd Asona, Triton, Pool Panel VG, are trade marks of Asona Ltd,

*All dimensions are nominal. We reserve the right to change specifications. Ref. Pool Panel VG IM-26.06

Asona Ltd. Office & Factory New Zealand Australia
6 Mahunga Drive, Māngere T: +64(0)9 525 6575 T: 1 800 240361
Bridge, Auckland 2022 E: info@asona.co.nz E: info@asona.com.au
New Zealand W: www.asona.co.nz W: www.asona.com.au
NZBN: 9429036035175

asona

triton pool panel vg™

High Sound Absorbing Ceiling Panel for Swimming Pools

3.0 Components & Ancillary Products

Pool Panel

(Back view of panel shown showing foil and folded edges)

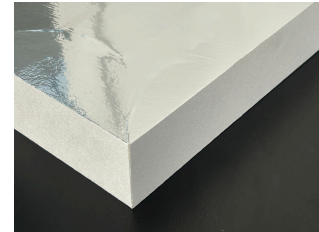

Standard Aluminium Side Impaling Bracket (ASIB)

To prevent galvanic corrosion, aluminium brackets are powder coated



Rivets

Ø4.0mm x 10-13mm dome head Aluminium Pop Rivets



Screws - fixing to timber

4 x 40 mm countersunk 1.4529 grade Stainless Steel Screw



Screws - fixing to steel

Consult with design engineer

Subframe

Aluminium Z Bar Section 25 x 50 x 25 x 2.5mm
Powder coated or anodised Marine Grade 25 micron minimum



Suspension subframe

Aluminium Angle Section 30 x 30 x 3.0mm
Powder coated or anodised Marine Grade 25 micron minimum

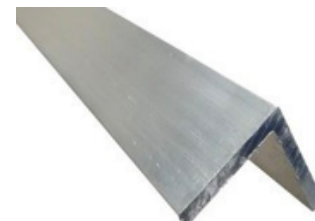

ISO 9001:2015 Registered Firm No. NZ1014

© 2026 Copyright ASONA Ltd Asona, Triton, Pool Panel VG, are trade marks of Asona Ltd,

*All dimensions are nominal. We reserve the right to change specifications.
Ref. Pool Panel VG IM-26.06

Asona Ltd. Office & Factory
6 Mahunga Drive, Māngere
Bridge, Auckland 2022
New Zealand
NZBN: 9429036035175

New Zealand
T: +64(0)9 525 6575
E: info@asona.co.nz
W: www.asona.co.nz

Australia
T: 1 800 240361
E: info@asona.com.au
W: www.asona.com.au

asona

triton pool panel vg™

High Sound Absorbing Ceiling Panel for Swimming Pools

3.0 Components & Ancillary Products, cont.

Cup Isolating Washer

Used to isolate stainless steel countersunk head timber screw
Isolating Cup Washer item (Item # FIX-Hi-Q 03-SWS0905)



Flat Isolating Washer

Used to isolate counter sunk stainless steel fixing screws from the
aluminium Z bracket.
M5 x 19 x 2.4mm (Item # FIX-Hi-Q 03-PNW5/19B)



Concrete Anchor - 30 x 30 x 3 mm angle to concrete fixing

M6 x 40mm 316 Stainless steel concrete anchor



ISO 9001:2015 Registered Firm No. NZ1014

© 2026 Copyright ASONA Ltd Asona, Triton, Pool Panel VG, are trade marks of Asona Ltd,

*All dimensions are nominal. We reserve the right to change specifications.
Ref. Pool Panel VG IM-26.06

Asona Ltd. Office & Factory
6 Mahunga Drive, Māngere
Bridge, Auckland 2022
New Zealand
NZBN: 9429036035175

New Zealand

T: +64(0)9 525 6575

E: info@asona.co.nz

W: www.asona.co.nz

Australia

T: 1 800 240361

E: info@asona.com.au

W: www.asona.com.au

asona

triton pool panel vg™

High Sound Absorbing Ceiling Panel for Swimming Pools

4.0 Installation

4.1 Standard Method

The preferred installation method is to mount Triton Pool Panel VG with the Aluminium Side Impaling Brackets (ASIB) to the 50mm Z bars that are fixed to the building structure (eg portal beams, concrete, purlins).

Direct Fixed Installation of Asona Triton Pool Panels VG to Existing Building Framework or Substrate

Installation shall not commence until the building is watertight and dry.

Installation Overview:

Set out panel panels to ensure a minimum gap of 50mm is achieved between all edges of the panels. Fix Z Bars to the structure then Pool Panels to the Z Bars. Use a laser or string lines to keep lines plumb and square on the structure/substrate for the location of the Z Bars.

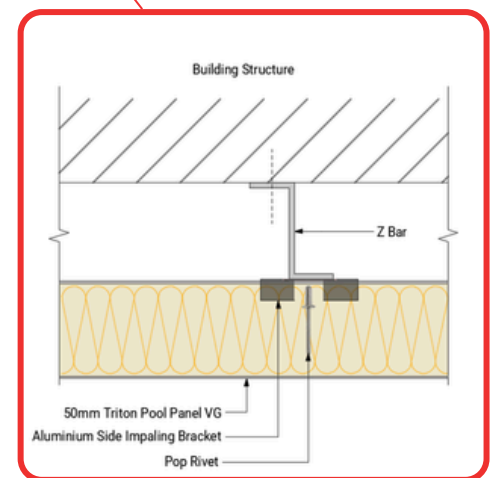
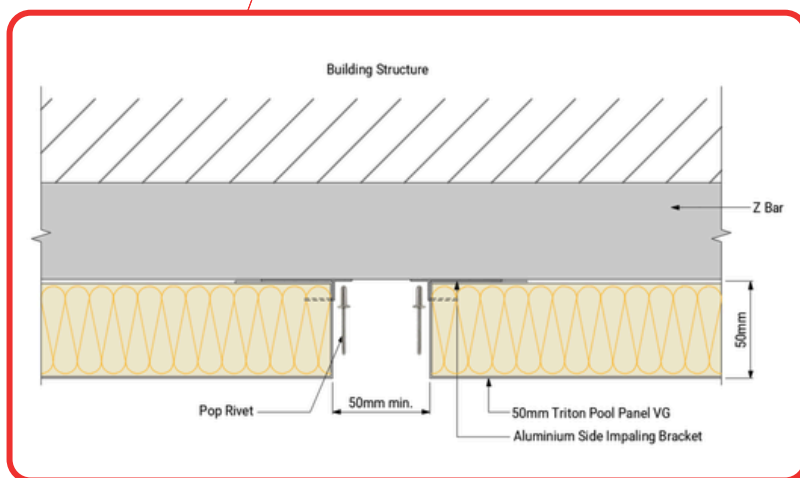
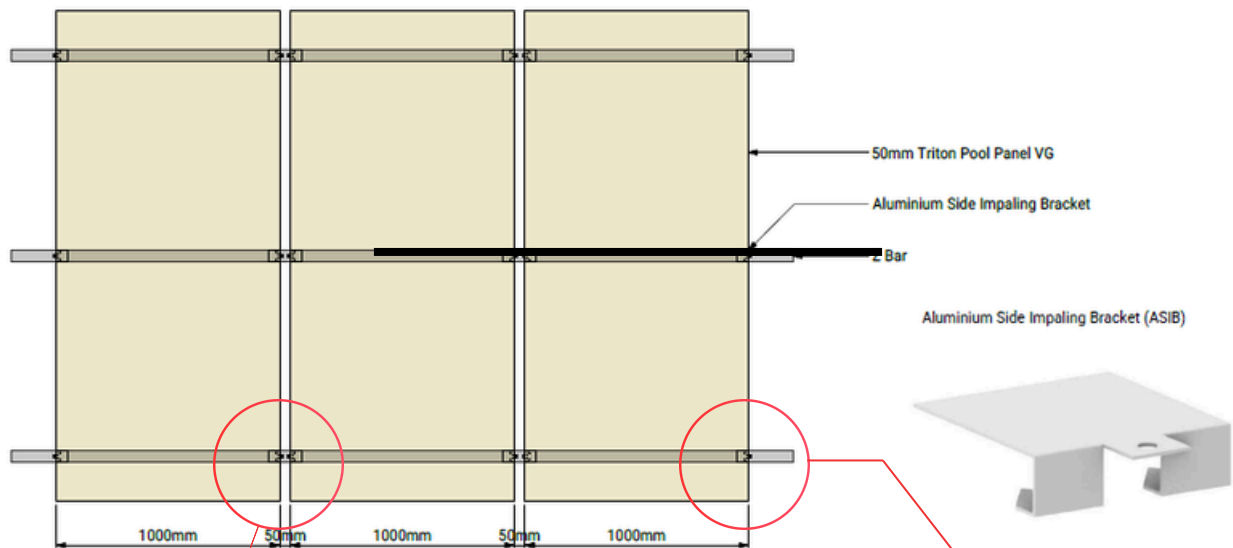

ISO 9001:2015 Registered Firm No. NZ1014

© 2026 Copyright ASONA Ltd Asona, Triton, Pool Panel VG, are trade marks of Asona Ltd,

*All dimensions are nominal. We reserve the right to change specifications. Ref. Pool Panel VG IM-26.06

Asona Ltd. Office & Factory
6 Mahunga Drive, Māngere
Bridge, Auckland 2022
New Zealand
NZBN: 9429036035175

New Zealand

T: +64(0)9 525 6575

E: info@asona.co.nz

W: www.asona.co.nz

Australia

T: 1 800 240361

E: info@asona.com.au

W: www.asona.com.au

asona

triton pool panel vg™

High Sound Absorbing Ceiling Panel for Swimming Pools

4.0 Installation

4.1 Standard Method

The preferred installation method is to mount Triton Pool Panel VG with the Aluminium Side Impaling Brackets (ASIB) to the 50mm Z bars that are fixed to the building structure (eg portal beams, concrete, purlins).

Direct Fixed Installation of Asona Triton Pool Panels VG to Existing Building Framework or Substrate

Installation shall not commence until the building is watertight and dry.

Installation of Z Bars:

Fix Z Bars to the structure using the appropriate fastener as detailed below.

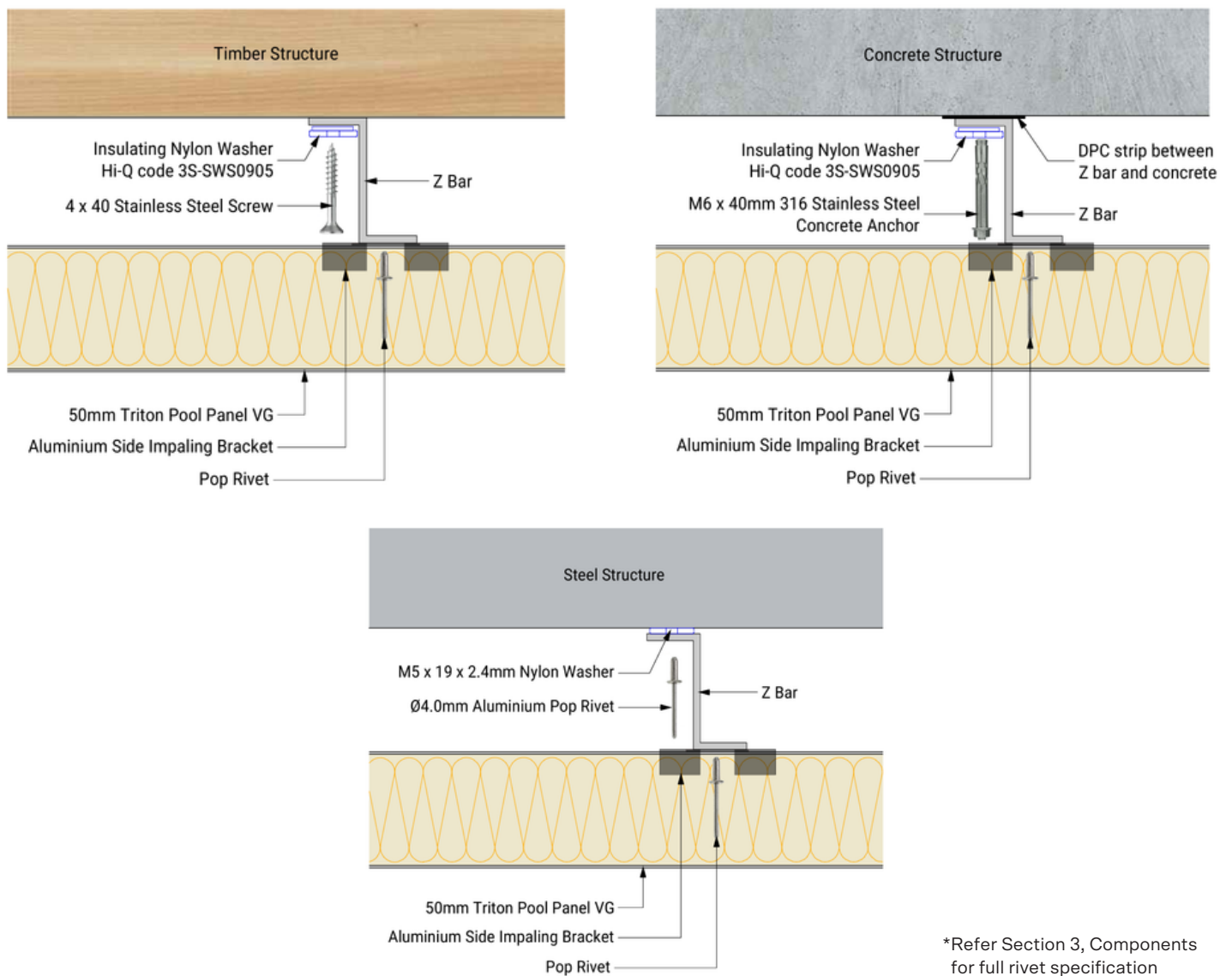

*Refer Section 3, Components for full rivet specification

ISO 9001:2015 Registered Firm No. NZ1014

© 2026 Copyright ASONA Ltd Asona, Triton, Pool Panel VG, are trade marks of Asona Ltd,

*All dimensions are nominal. We reserve the right to change specifications. Ref. Pool Panel VG IM-26.06

Asona Ltd. Office & Factory
6 Mahunga Drive, Māngere
Bridge, Auckland 2022
New Zealand
NZBN: 9429036035175

New Zealand

T: +64(0)9 525 6575

E: info@asona.co.nz

W: www.asona.co.nz

Australia

T: 1 800 240361

E: info@asona.com.au

W: www.asona.com.au

asona

triton pool panel vg™

High Sound Absorbing Ceiling Panel for Swimming Pools

4.0 Installation

ASIB Bracket Positioning:

Panels are supported at sides to align with Z Bar subframe position

For panels lengths 600 – 1200mm, 4 brackets / 2 Z Bars shall be used.
 For panels lengths 1800 – 2350mm, 6 brackets / 3 Z Bars shall be used.
 For panels lengths 2800mm, 8 brackets / 4 Z Bars shall be used.
 Ensure the Pool Panel is laid flat on a clean dry surface when attaching brackets.

- Position and install brackets 100 to 150mm from the corner of the panel with others central or evenly spaced.

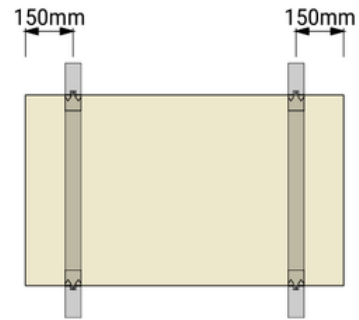

For panel lengths – 600 - 1200mm
4 brackets / 2 Z bars shall be used

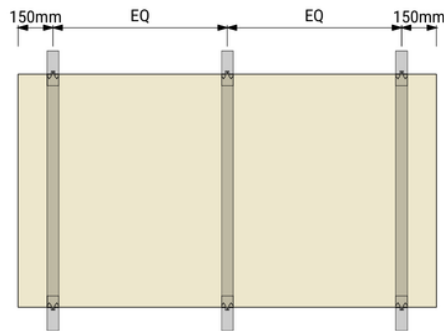

For panel lengths – 1800 - 2350mm
6 brackets / 3 Z bars shall be used

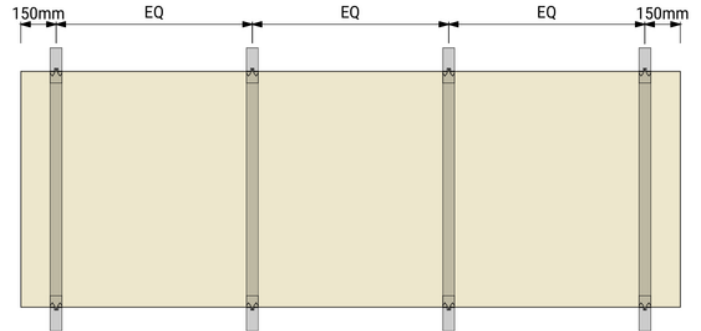

For panel lengths – 2800mm
8 brackets / 4 Z bars shall be used

Aluminium Side Impaling Bracket Attachment:

Lay the ASIB on the back of the Pool Panel VG in the required location. Using a side to side rocking motion, push the barbs into the side of the Pool Panel, ensuring it is fully inserted against the back edge of the ASIB.

SIB positioned

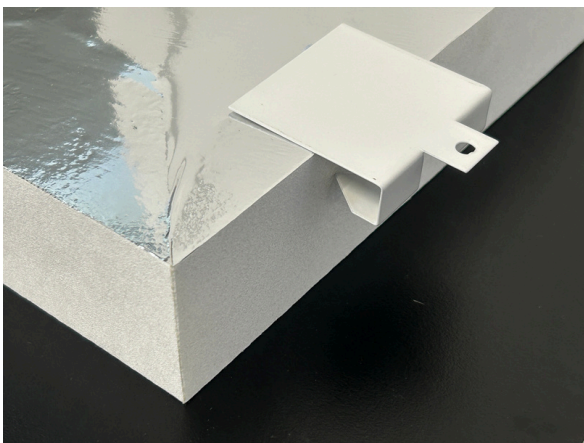

SIB fully inserted

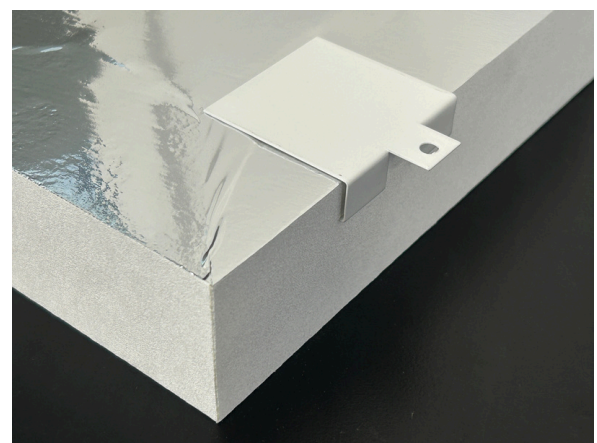

ISO 9001:2015 Registered Firm No. NZ1014

© 2026 Copyright ASONA Ltd Asona, Triton, Pool Panel VG, are trade marks of Asona Ltd,

*All dimensions are nominal. We reserve the right to change specifications.
 Ref. Pool Panel VG IM-26.06

Asona Ltd. Office & Factory
 6 Mahunga Drive, Māngere
 Bridge, Auckland 2022
 New Zealand
 NZBN: 9429036035175

New Zealand

T: +64(0)9 525 6575

E: info@asona.co.nz

W: www.asona.co.nz

Australia

T: 1 800 240361

E: info@asona.com.au

W: www.asona.com.au

asona

triton pool panel vg™

High Sound Absorbing Ceiling Panel for Swimming Pools

4.0 Installation

Note: Wear white cotton gloves to prevent soiling of the Pool Panel finish.

Panel Installation

Lift the Pool Panels into position using 2 people or a panel lifter to support the panel. Align the ASIB brackets with the installed Z Bar and drill with a 4.5mm drill through the ASIB hole into the Z Bar. Secure with aluminium rivets.

Refer to Section 3, Components schedule for full rivet specification.



Panel Attachment to Z Bar:

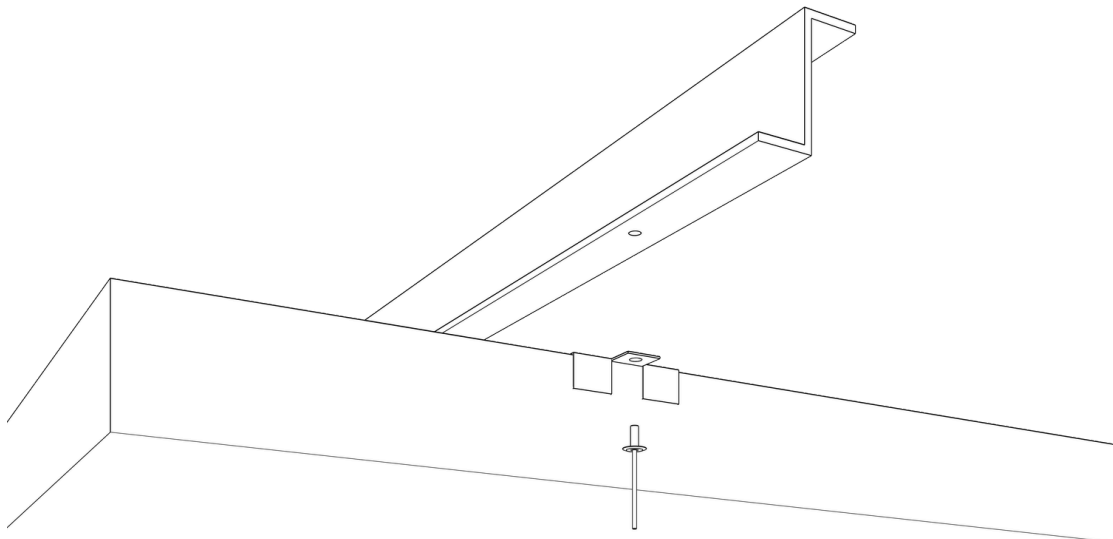

ISO 9001:2015 Registered Firm No. NZ1014

© 2026 Copyright ASONA Ltd Asona, Triton, Pool Panel VG, are trade marks of Asona Ltd,

*All dimensions are nominal. We reserve the right to change specifications.
Ref. Pool Panel VG IM-26.06

Asona Ltd. Office & Factory
6 Mahunga Drive, Māngere
Bridge, Auckland 2022
New Zealand
NZBN: 9429036035175

New Zealand

T: +64(0)9 525 6575

E: info@asona.co.nz

W: www.asona.co.nz

Australia

T: 1 800 240361

E: info@asona.com.au

W: www.asona.com.au

asona

triton pool panel vg™

High Sound Absorbing Ceiling Panel for Swimming Pools

4.0 Installation

4.2 Installing Suspended Asona Triton Pool Panels VG

Installation shall not commence until the building is watertight and dry.

Installation Overview:

Where the suspension of an installation is required, set out using aluminium L angle sections at centres to suit the Asona Triton Pool Panel Z Bar sub frame, including any seismic bracing requirements. L angle hanger shall be at nominal 1200mm centres maximum.

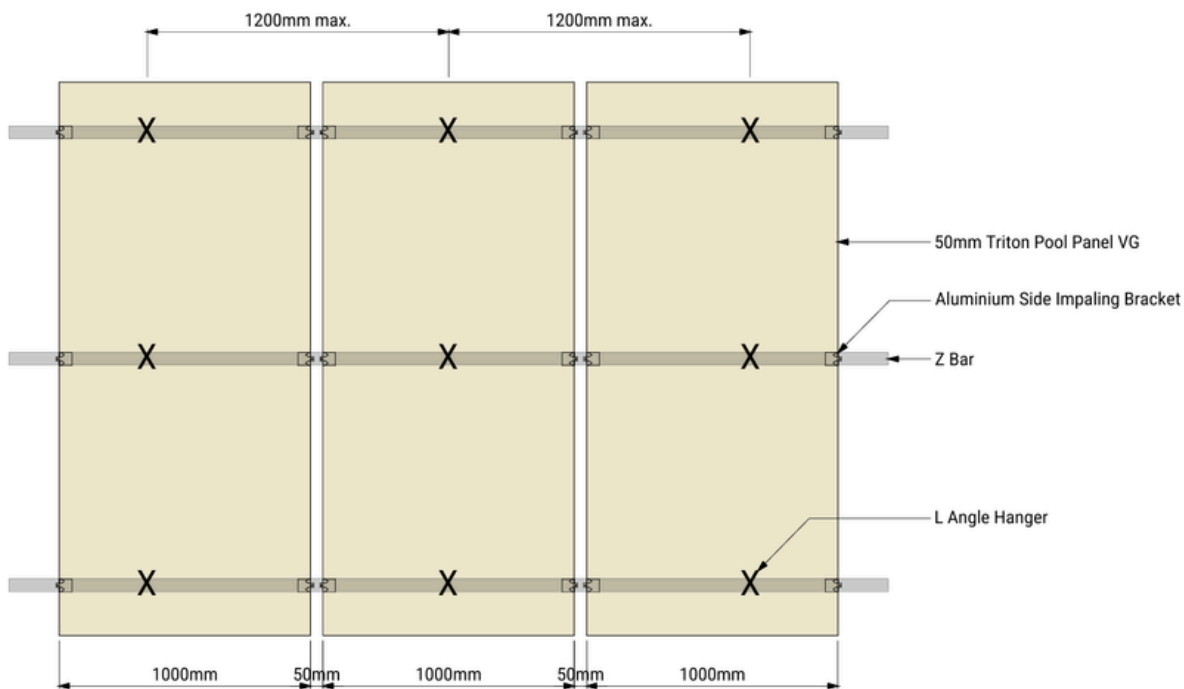

L Angle Hanger Attachment to Z Bar:

Use 2 x Ø4.0mm x 10-13mm dome head Aluminium Pop Rivets

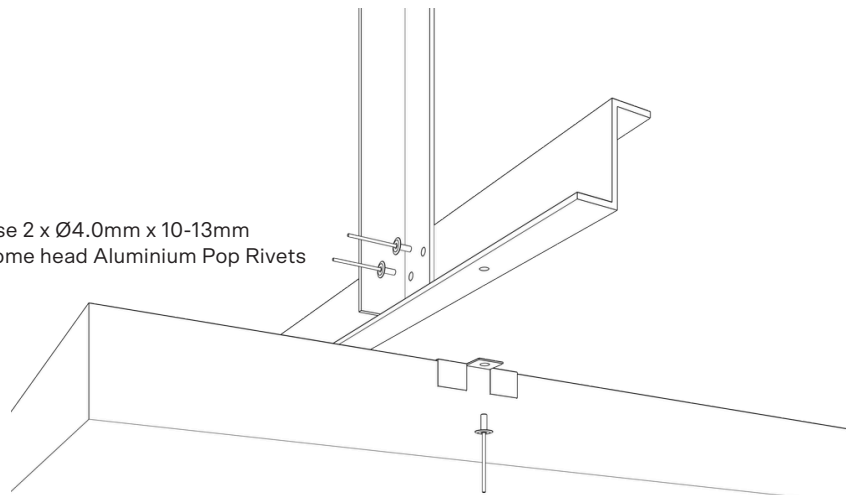

ISO 9001:2015 Registered Firm No. NZ1014

© 2026 Copyright ASONA Ltd Asona, Triton, Pool Panel VG, are trade marks of Asona Ltd,

*All dimensions are nominal. We reserve the right to change specifications. Ref. Pool Panel VG IM-26.06

Asona Ltd. Office & Factory
6 Mahunga Drive, Māngere
Bridge, Auckland 2022
New Zealand
NZBN: 9429036035175

New Zealand

T: +64(0)9 525 6575

E: info@asona.co.nz

W: www.asona.co.nz

Australia

T: 1 800 240361

E: info@asona.com.au

W: www.asona.com.au

asona

triton pool panel vg™

High Sound Absorbing Ceiling Panel for Swimming Pools

4.0 Installation

Installing Asona Triton Pool Panels VG with Suspended Aluminium L Angle

Suspension Construction Detail:

Construct suspension using powder coated or Marine Grade anodised 30 x 30 x 3.0mm Aluminium hangers. Ensure the layout of the suspension coincides with the Z Bar positions.

Determine the required height to allow for the thickness of the panel plus Z Bar depth eg 50mm Pool Panel + 50mm Z Bar = 100mm above specified FCL height.

Install solid L angle hangers at 1200mm centres maximum along the length of the Z Bar section subframe.

To a Concrete Structure:

When fixing to the underside of concrete attach the aluminium angle using a M6 x 40mm 316 Stainless steel concrete anchor. Use a strip of DPC between the aluminium angle and concrete structure. Ensure the insulating washer is between the head of the concrete anchor and the aluminium angle.

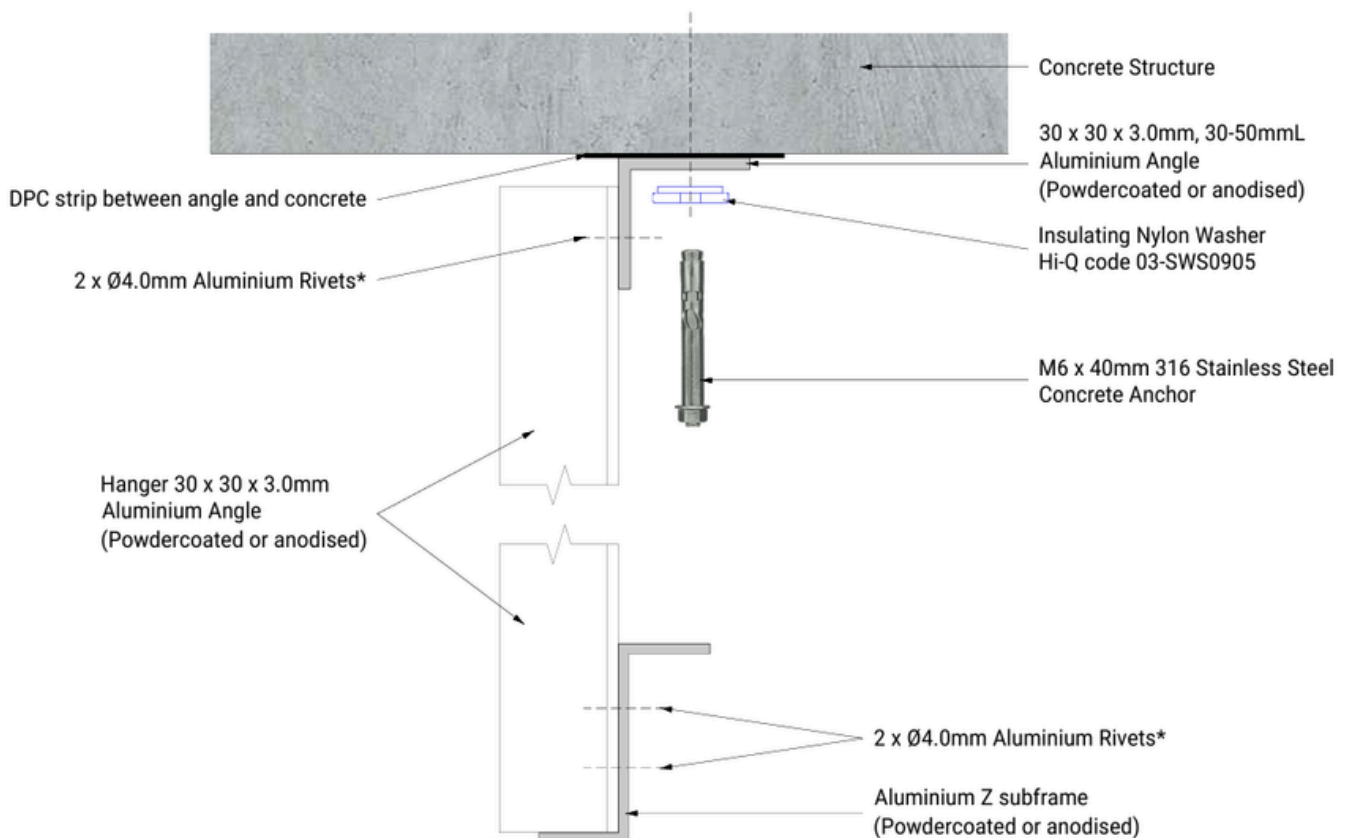

*Refer Section 3, Components for full rivet specification

ISO 9001:2015 Registered Firm No. NZ1014

© 2026 Copyright ASONA Ltd Asona, Triton, Pool Panel VG, are trade marks of Asona Ltd,

*All dimensions are nominal. We reserve the right to change specifications. Ref. Pool Panel VG IM-26.06

Asona Ltd. Office & Factory
6 Mahunga Drive, Māngere
Bridge, Auckland 2022
New Zealand
NZBN: 9429036035175

New Zealand

T: +64(0)9 525 6575

E: info@asona.co.nz

W: www.asona.co.nz

Australia

T: 1 800 240361

E: info@asona.com.au

W: www.asona.com.au

asona

triton pool panel vg™

High Sound Absorbing Ceiling Panel for Swimming Pools

4.0 Installation

Installing Asona Triton Pool Panels VG with Suspended Aluminium L Angle

Subframe Construction Detail:

Construct suspension using powder coated or Marine Grade anodised 30 x 30 x 3.0mm Aluminium hangers. Ensure the layout of the suspension coincides with the Z Bar positions.

Determine the required height to allow for the thickness of the panel plus Z Bar depth eg 50mm Pool Panel + 50mm Z Bar = 100mm above specified FCL height.

Install solid L angle hangers at 1200mm centres maximum along the length of the Z Bar section subframe.

To a Timber Structure:

When fixing to the underside of timber attach the aluminium angle using 40 mm 1.4529 grade Stainless Steel Screw with nylon washers. Ensure the nylon washer is between the head of the screw and the aluminium angle.

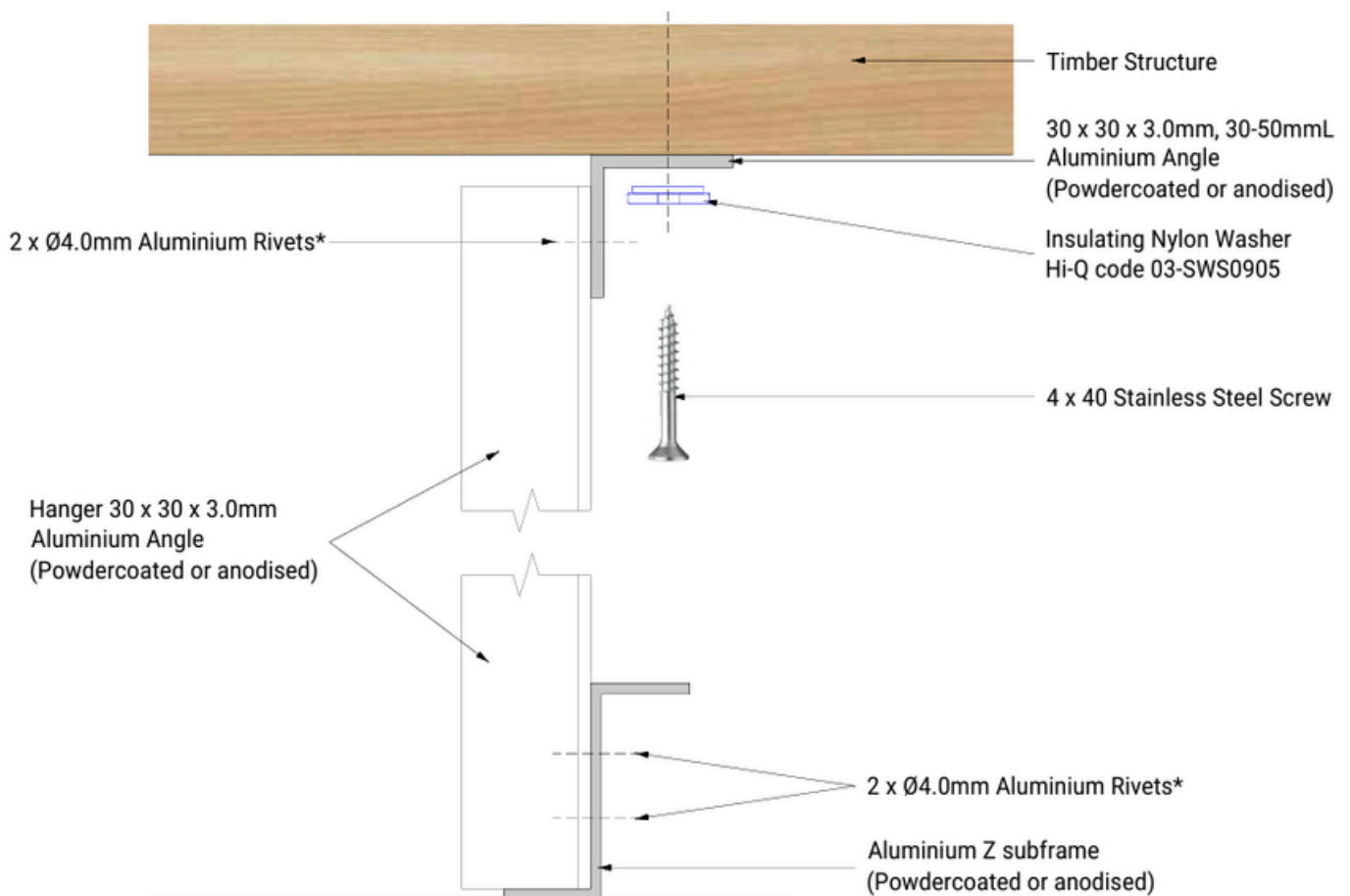

*Refer Section 3, Components for full rivet specification

ISO 9001:2015 Registered Firm No. NZ1014

© 2026 Copyright ASONA Ltd Asona, Triton, Pool Panel VG, are trade marks of Asona Ltd,

*All dimensions are nominal. We reserve the right to change specifications. Ref. Pool Panel VG IM-26.06

Asona Ltd. Office & Factory
6 Mahunga Drive, Māngere
Bridge, Auckland 2022
New Zealand
NZBN: 9429036035175

New Zealand

T: +64(0)9 525 6575

E: info@asona.co.nz

W: www.asona.co.nz

Australia

T: 1 800 240361

E: info@asona.com.au

W: www.asona.com.au

asona

triton pool panel vg™

High Sound Absorbing Ceiling Panel for Swimming Pools

4.0 Installation

Installing Asona Triton Pool Panels VG with Suspended Aluminium L Angle

Subframe Construction Detail:

Construct suspension using powder coated or Marine Grade anodised 30 x 30 x 3.0mm Aluminium hangers. Ensure the layout of the suspension coincides with the Z Bar positions.

Determine the required height to allow for the thickness of the panel plus Z Bar depth eg 50mm Pool Panel + 50mm Z Bar = 100mm above specified FCL height.

Install solid L angle hangers at 1200mm centres maximum along the length of the Z Bar section subframe.

To a Steel Structure:

When fixing to the underside of a Steel Purlin or primary steel structure, attach the aluminium angle using 2 x Ø4.0mm Aluminium Rivets. Ensure the insulating washer is between the steel and the aluminium angle. Coat exposed rivet with corrosion resistant paint.

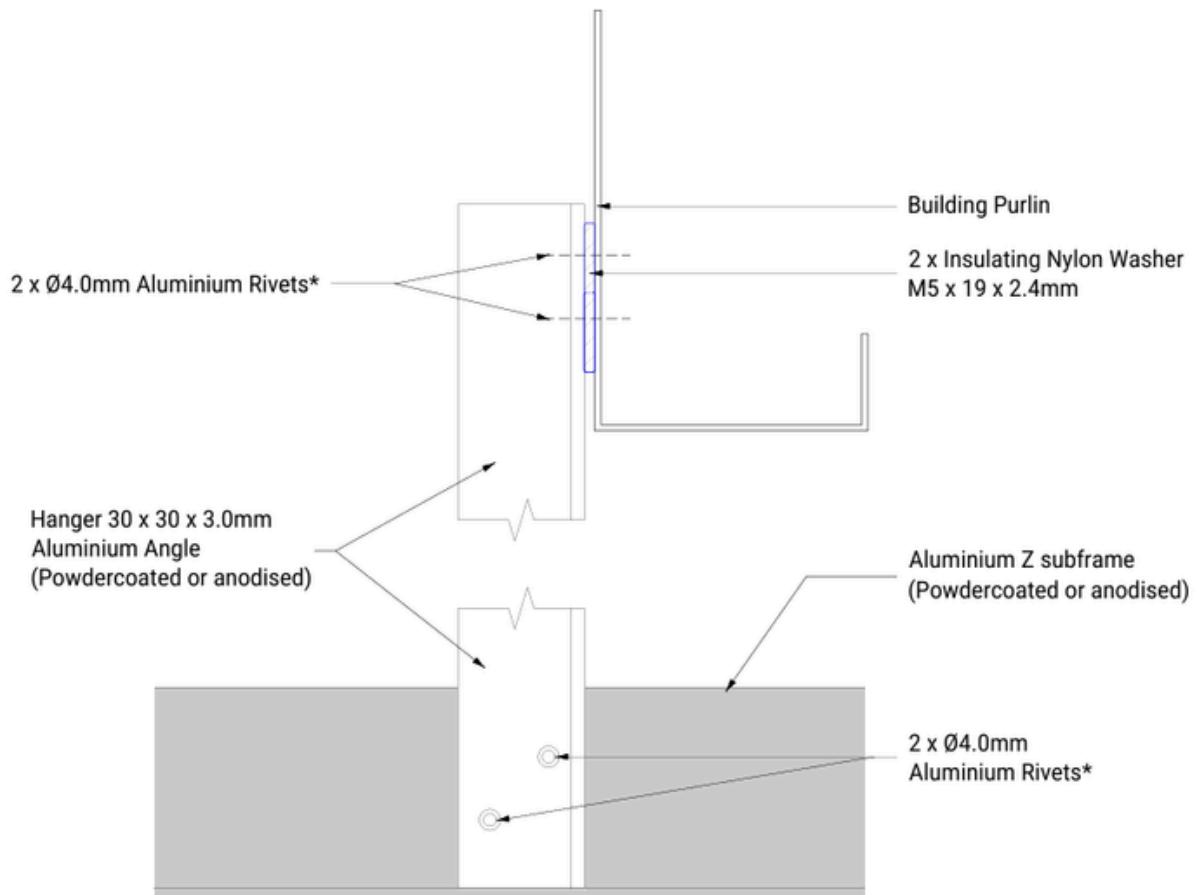

*Refer Section 3, Components for full rivet specification

ISO 9001:2015 Registered Firm No. NZ1014

© 2026 Copyright ASONA Ltd Asona, Triton, Pool Panel VG, are trade marks of Asona Ltd,

*All dimensions are nominal. We reserve the right to change specifications. Ref. Pool Panel VG IM-26.06

Asona Ltd. Office & Factory New Zealand Australia
6 Mahunga Drive, Māngere T: +64(0)9 525 6575 T: 1 800 240361
Bridge, Auckland 2022 E: info@asona.co.nz E: info@asona.com.au
New Zealand W: www.asona.co.nz W: www.asona.com.au
NZBN: 9429036035175

asona

triton pool panel vg™

High Sound Absorbing Ceiling Panel for Swimming Pools

4.0 Installation

Installing Asona Triton Pool Panels VG with Suspended Aluminium L Angle

Subframe Construction Detail:

Construct suspension using powder coated or Marine Grade anodised 30 x 30 x 3.0mm Aluminium hangers. Ensure the layout of the suspension coincides with the Z Bar positions.

Determine the required height to allow for the thickness of the panel plus Z Bar depth eg 50mm Pool Panel + 50mm Z Bar = 100mm above specified FCL height.

Install solid L angle hangers at 1200mm centres maximum along the length of the Z Bar section subframe.

To a Sheet Lined Suspended Ceiling:

When fixing to the underside of a suspended ceiling with sheet lining, attach the aluminium angle bracket through the lining into the ceiling frame using 1.4529 grade Stainless Steel Screw suitable for light gauge steel (up to 0.75 BMT), with a nylon washer. Ensure the nylon washer is between the head of the screw and the aluminium angle.

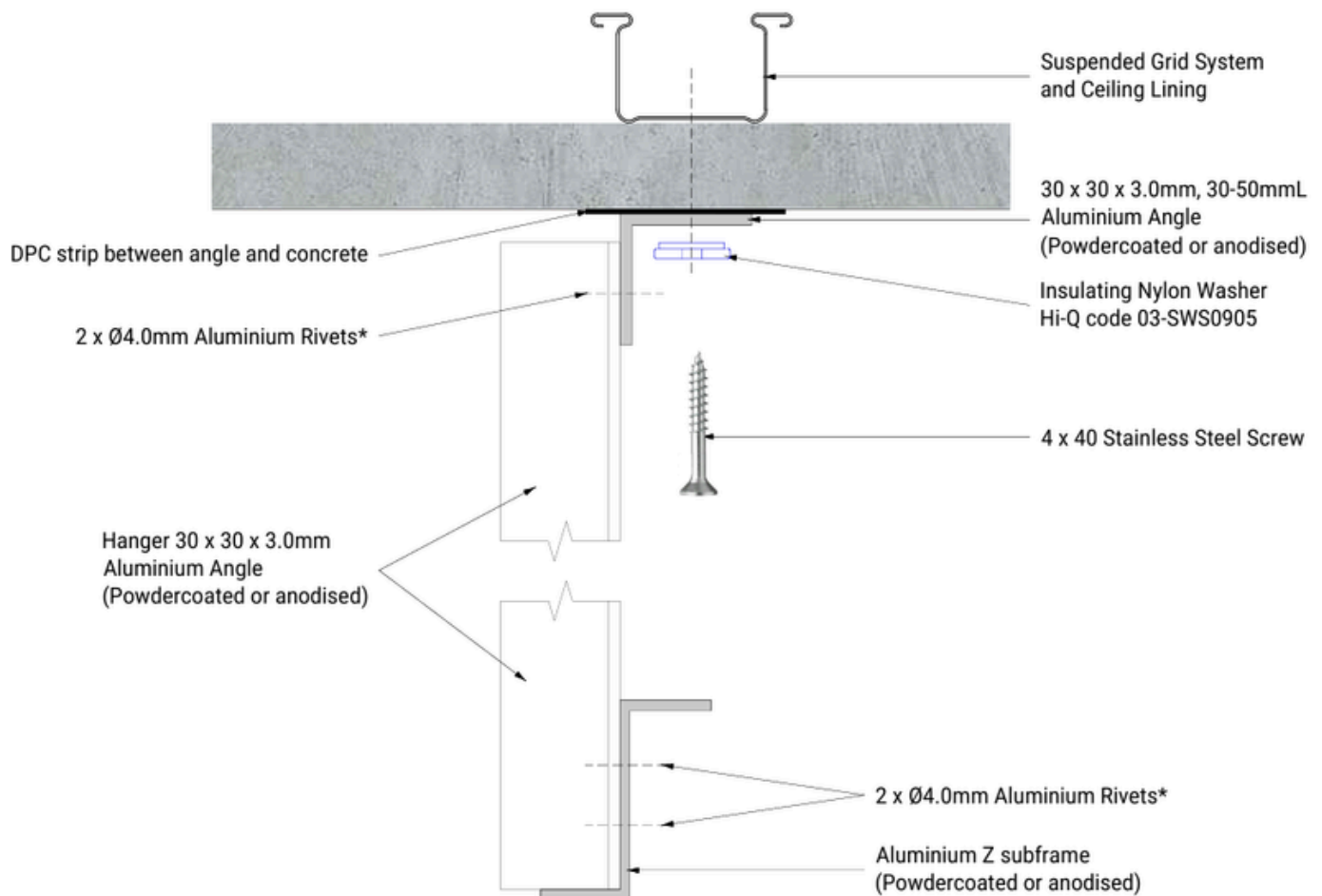

*Refer Section 3, Components for full rivet specification

ISO 9001:2015 Registered Firm No. NZ1014

© 2026 Copyright ASONA Ltd Asona, Triton, Pool Panel VG, are trade marks of Asona Ltd,

*All dimensions are nominal. We reserve the right to change specifications. Ref. Pool Panel VG IM-26.06

Asona Ltd. Office & Factory
6 Mahunga Drive, Māngere
Bridge, Auckland 2022
New Zealand
NZBN: 9429036035175

New Zealand

T: +64(0)9 525 6575

E: info@asona.co.nz

W: www.asona.co.nz

Australia

T: 1 800 240361

E: info@asona.com.au

W: www.asona.com.au

asona

triton pool panel vg™

High Sound Absorbing Ceiling Panel for Swimming Pools

4.0 Installation

Installing Asona Triton Pool Panels to a Suspended Aluminium Subframe—cont.

Note: Wear white cotton gloves to prevent soiling of the Pool Panel finish.

Panel Installation

Lift the Pool Panels into position using 2 people or a panel lifter to support the panel. Fix off to the Z subframe.



Panel Attachment:

Install the Pool Panel to the Z Bar Subframe. Fix using 1 x Ø4.0mm aluminium rivet through all of the Aluminium Side Impaling Brackets

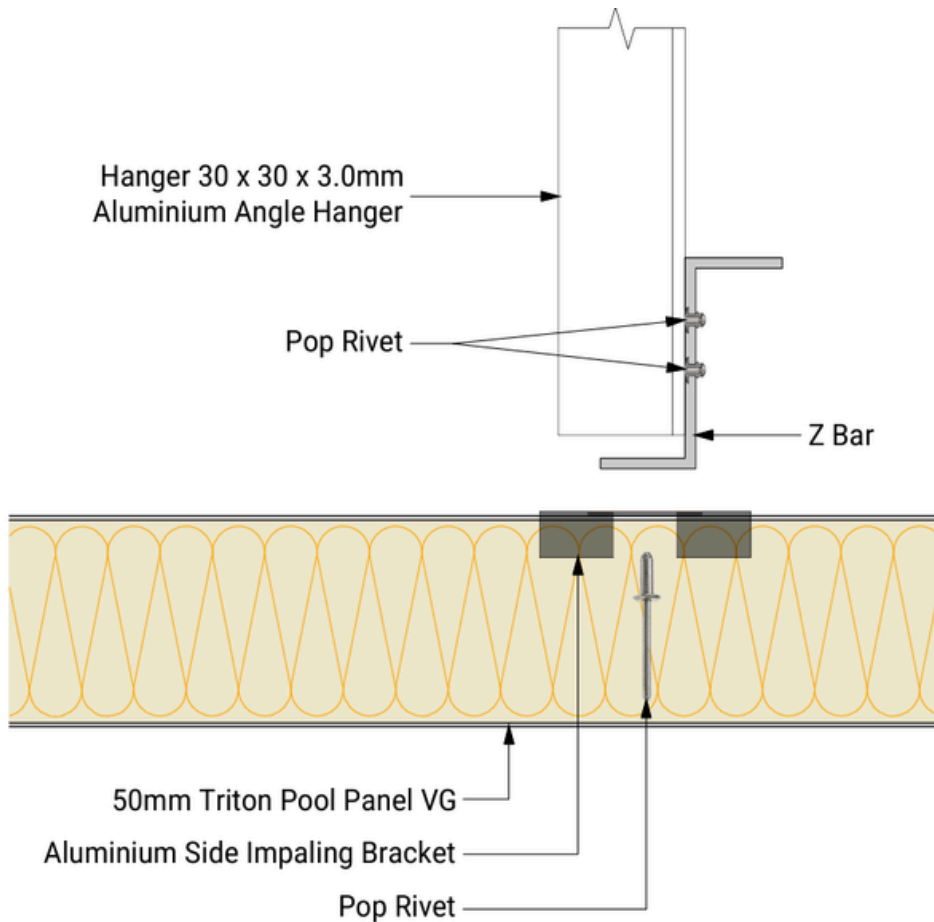

*Refer Section 3, Components for full rivet specification

ISO 9001:2015 Registered Firm No. NZ1014

© 2026 Copyright ASONA Ltd Asona, Triton, Pool Panel VG, are trade marks of Asona Ltd,

*All dimensions are nominal. We reserve the right to change specifications. Ref. Pool Panel VG IM-26.06

Asona Ltd. Office & Factory
6 Mahunga Drive, Māngere
Bridge, Auckland 2022
New Zealand
NZBN: 9429036035175

New Zealand

T: +64(0)9 525 6575

E: info@asona.co.nz

W: www.asona.co.nz

Australia

T: 1 800 240361

E: info@asona.com.au

W: www.asona.com.au

asona

triton pool panel vg™

High Sound Absorbing Ceiling Panel for Swimming Pools

4.0 Installation

4.3 Installation of Services and Penetrations

Mechanical and electrical services and fire sprinklers shall ideally be positioned between panels and attached to the structure independent of the Triton Pool Panel VG. Adjust panel sizes to accommodate services.

Where this is not possible, surface mounted lightweight fittings less than 1 kg, (such as smoke detectors), point loads shall be independently supported. A common method is to place a treated timber batten across the back of the panel, edge to edge. Screw through the panel into the batten using 1.4529 grade Stainless Steel Screw.

Take care not to over tighten screws or to compress the face.

Penetrations through the panels must have sufficient clearance around the penetration that they cannot be in contact with the Triton Pool Panel VG.

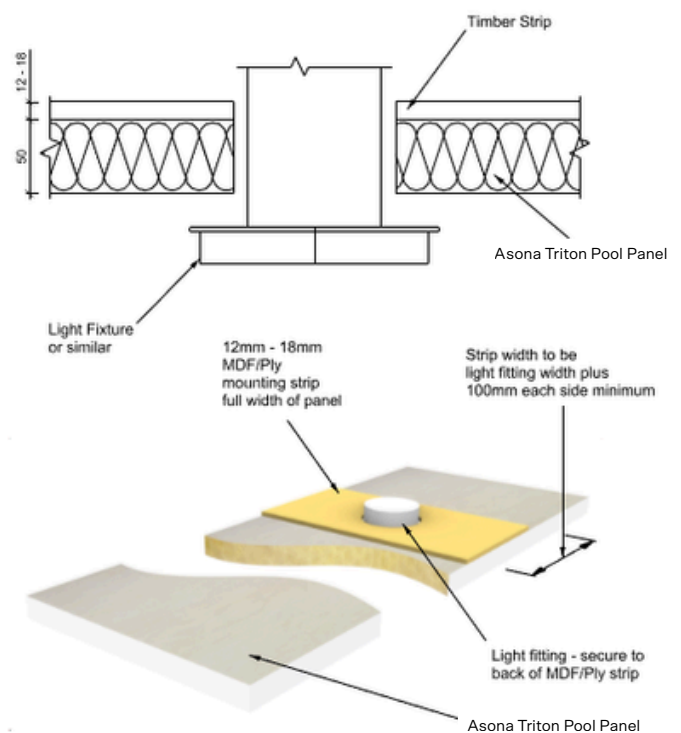
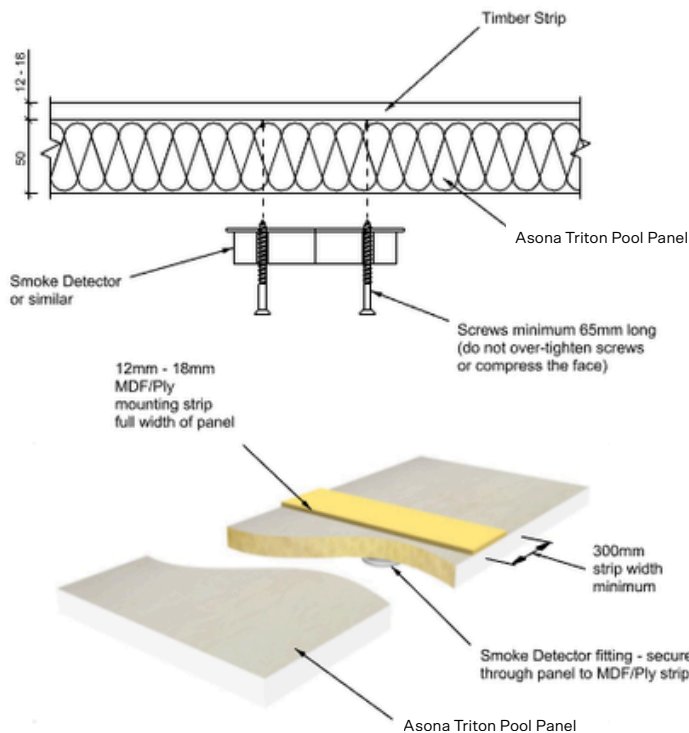

4.4 Access Panels

Access panels in Triton Pool panels shall be avoided where possible. Screw fixed panels may be demounted to gain access above. Consult Asona.

ISO 9001:2015 Registered Firm No. NZ1014

© 2026 Copyright ASONA Ltd Asona, Triton, Pool Panel VG, are trade marks of Asona Ltd,

*All dimensions are nominal. We reserve the right to change specifications. Ref. Pool Panel VG IM-26.06

Asona Ltd. Office & Factory
6 Mahunga Drive, Māngere
Bridge, Auckland 2022
New Zealand
NZBN: 9429036035175

New Zealand

T: +64(0)9 525 6575

E: info@asona.co.nz

W: www.asona.co.nz

Australia

T: 1 800 240361

E: info@asona.com.au

W: www.asona.com.au

asona

triton pool panel vg™

High Sound Absorbing Ceiling Panel for Swimming Pools

5.0 Cutting

5.0 Cutting

Cutting of panels shall be avoided where possible.
Custom made to measure panels are available, consult Asona.

If cutting of panels is required to adjust for onsite dimension, then you will need to follow the methods below. As any cut through the panel will expose the acoustic core, this step-by-step guide illustrates the tools and method required to trim and recover the exposed core of the Triton Pool VG panels to maintain a consistent edge finish. There are two methods available, crease and fold (CF) or edge band (EB). For cuts less than 50 mm, diagonal, and notched cuts, you will need to use the edge band method and purchase edge banding strips from Asona prior to carrying out works.

For additional assistance please consult Asona technical team.

Set up

Set up a clean work bench or cutting table with a clean flat surface, drop sheet to floor. Best cutting results are achieved when using a bench saw or plunge saw with guidance rail. Use a fine-tooth cutting blade and dust extractor. Protect the panel face with a cover sheet.

CF1 Site measure and marking

- Note: For trim cuts less than 50 mm you will need to purchase and apply a Sonatex edge band strip. Refer to Edge Banding method in this document.
- Site measure the cut size required.
 - Place the panel face down on the cutting table and measure actual thickness, this will determine the 2nd mark position.
 - Make 2 marks on the back of the panel. These mark the position for 2 saw cuts. Do not mark the face side.
 - The first mark will be the location for the finished trim size. Mark this dimension to the back of the panel using a straight edge and pencil.
 - Make a second mark line 49-50 mm from the 1st line, this will be closer to the 'cut to waste' side.

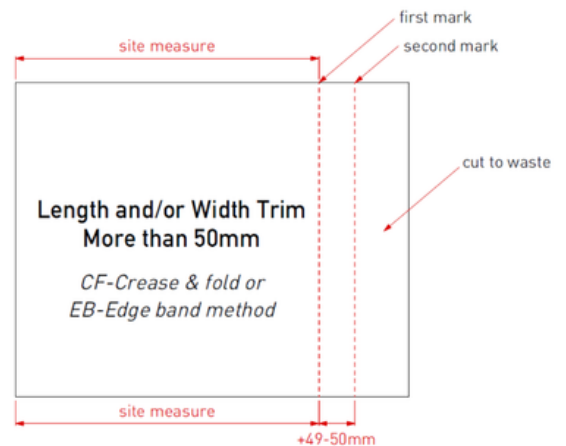

CF2 Cutting - cut to waste:

- Position the guide rail on the back of the panel to align with the 2nd marked line
- Set saw cut depth to 51-55 mm and carefully cut through the panel.
- Discard offcut to waste.



ISO 9001:2015 Registered Firm No. NZ1014

© 2026 Copyright ASONA Ltd Asona, Triton, Pool Panel VG, are trade marks of Asona Ltd,

*All dimensions are nominal. We reserve the right to change specifications.
Ref. Pool Panel VG IM-26.06

Asona Ltd. Office & Factory
6 Mahunga Drive, Māngere
Bridge, Auckland 2022
New Zealand
NZBN: 9429036035175

New Zealand

T: +64(0)9 525 6575

E: info@asona.co.nz

W: www.asona.co.nz

Australia

T: 1 800 240361

E: info@asona.com.au

W: www.asona.com.au

asona

triton pool panel vg™

High Sound Absorbing Ceiling Panel for Swimming Pools

5.0 Cutting

CF3 Cutting - cut to finish size:

- Reposition the guide rail to align to the 1st mark.

- Check the thickness of the panel and set the depth of the plunge saw to leave no less than 2.0mm from the face of the panel.

NB: Take care not to cut through the Sonatex™ facing material as this is required to be folded and cover the acoustic core.



CF4 Removing the cut core:

- Use the utility knife blade and position horizontally. Using a 'filleting' action carefully cut between the Sonatex and the acoustic core. Take care not to cut into the facing.



ISO 9001:2015 Registered Firm No. NZ1014

© 2026 Copyright ASONA Ltd Asona, Triton, Pool Panel VG, are trade marks of Asona Ltd,

*All dimensions are nominal. We reserve the right to change specifications.
Ref. Pool Panel VG IM-26.06

Asona Ltd. Office & Factory
6 Mahunga Drive, Māngere
Bridge, Auckland 2022
New Zealand
NZBN: 9429036035175

New Zealand

T: +64(0)9 525 6575

E: info@asona.co.nz

W: www.asona.co.nz

Australia

T: 1 800 240361

E: info@asona.com.au

W: www.asona.com.au

asona

triton pool panel vg™

High Sound Absorbing Ceiling Panel for Swimming Pools

5.0 Cutting

CF4 Removing the cut core cont.:

- Remove the cut section of the acoustic core and discard to waste.



CF5 Cleaning up the back of the Sonatex:

- Use the scraper tool to remove any excess acoustic core that remains on the back of the Sonatex™ facing material.
- Take care not to damage the Sonatex facing material.

- The goal is to achieve a clean smooth surface.



ISO 9001:2015 Registered Firm No. NZ1014

© 2026 Copyright ASONA Ltd Asona, Triton, Pool Panel VG, are trade marks of Asona Ltd,

*All dimensions are nominal. We reserve the right to change specifications. Ref. Pool Panel VG IM-26.06

Asona Ltd. Office & Factory
6 Mahunga Drive, Māngere
Bridge, Auckland 2022
New Zealand
NZBN: 9429036035175

New Zealand

T: +64(0)9 525 6575

E: info@asona.co.nz

W: www.asona.co.nz

Australia

T: 1 800 240361

E: info@asona.com.au

W: www.asona.com.au

asona

triton pool panel vg™

High Sound Absorbing Ceiling Panel for Swimming Pools

5.0 Cutting

CF6 Creasing the back of the Sonatex™ facing:

- Use the putty knife to gently crease a fold line in the back of the Sonatex at the intersection with the acoustic core board.
- Make sure the blade is vertical and square to the core board.
- Use a slow and gentle scoring action and make 1 or 2 passes. **Do not over pressure the tool as this may cut through the facing.**
- Put on the clean gloves and carefully make a hand fold to check that the fold line is straight and that corners align with no gaps. Work from the centre to the edge.



CF7 Applying the adhesive:

- Spray contact adhesive to the exposed acoustic core and back of the Sonatex facing taking care not to over spray onto the decorative side. Use masking tape if required.
 - Spray a double pass to ensure sufficient adhesive coverage to ensure a strong bond.
 - Allow time for the adhesive to tack off (usually no longer than 2 minutes).
- N.B Check adhesive manufacture directions before applying adhesive.



ISO 9001:2015 Registered Firm No. NZ1014

© 2026 Copyright ASONA Ltd Asona, Triton, Pool Panel VG, are trade marks of Asona Ltd,

*All dimensions are nominal. We reserve the right to change specifications.
Ref. Pool Panel VG IM-26.06

Asona Ltd. Office & Factory
6 Mahunga Drive, Māngere
Bridge, Auckland 2022
New Zealand
NZBN: 9429036035175

New Zealand

T: +64(0)9 525 6575

E: info@asona.co.nz

W: www.asona.co.nz

Australia

T: 1 800 240361

E: info@asona.com.au

W: www.asona.com.au

asona

triton pool panel vg™

High Sound Absorbing Ceiling Panel for Swimming Pools

5.0 Cutting

CF8 CF8 Folding and fixing the new edge:

- Wearing clean white gloves and working from the centre, fold up the Sonatex facing to the acoustic core.
- Apply hand pressure to ensure a positive bond. Take care to ensure the corners align and are formed neatly.
- If any excess extends above the back of the panel then use a medium to fine (180- 220 grit) sanding block to buff and tidy the edge.

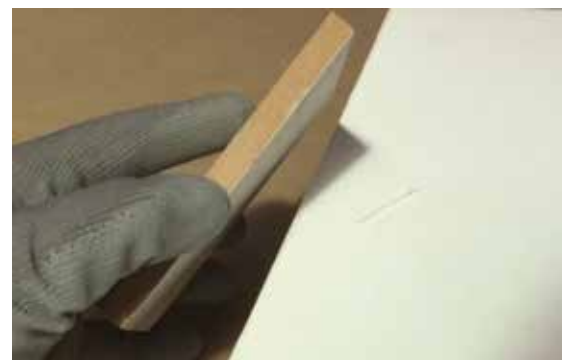

CF9 QA:

Turn the panel over and inspect the facing and the newly folded edge.

Carefully remove any over spray and clean up any finger marks by buffing the panel with a piece of Sonatex™ or 'magic sponge' cleaner.

The Triton Pool Panel VG is now ready for installation.



ISO 9001:2015 Registered Firm No. NZ1014

© 2026 Copyright ASONA Ltd Asona, Triton, Pool Panel VG, are trade marks of Asona Ltd,

*All dimensions are nominal. We reserve the right to change specifications.
Ref. Pool Panel VG IM-26.06

Asona Ltd. Office & Factory
6 Mahunga Drive, Māngere
Bridge, Auckland 2022
New Zealand
NZBN: 9429036035175

New Zealand

T: +64(0)9 525 6575

E: info@asona.co.nz

W: www.asona.co.nz

Australia

T: 1 800 240361

E: info@asona.com.au

W: www.asona.com.au

asona

triton pool panel vg™

High Sound Absorbing Ceiling Panel for Swimming Pools

5.0 Cutting

EB Edge Band method:

From time to time you may be required to trim less than 50 mm or make diagonal or notched cuts into the acoustic panel.

Use the edge banding method to achieve these on site.

You will need to pre-purchase Sonatex edge banding strips from Asona prior to carrying out works.

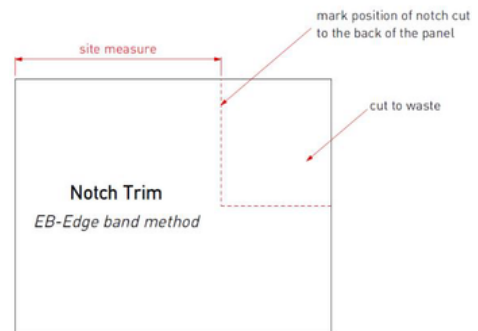
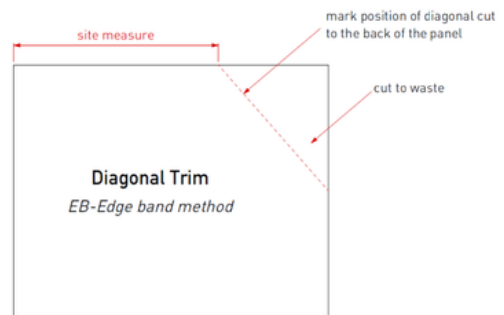
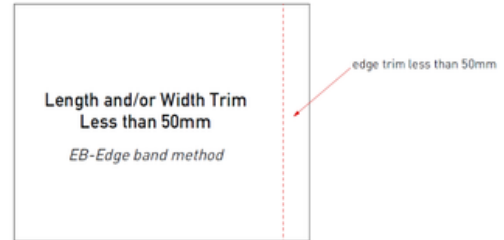

EB1 Cutting - cut to finish size:

- Site measure to determine the finished panel size. Mark the position on the back of the panel.
- Using the method as described in point CF2 above cut through the full depth of the panel with a plunge saw. The objective is to achieve straight square cut face. Discard offcut to waste.

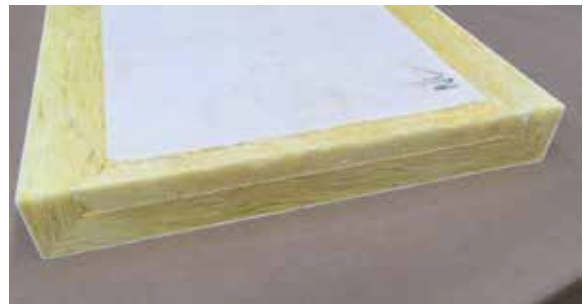

ISO 9001:2015 Registered Firm No. NZ1014

© 2026 Copyright ASONA Ltd Asona, Triton, Pool Panel VG, are trade marks of Asona Ltd,

*All dimensions are nominal. We reserve the right to change specifications. Ref. Pool Panel VG IM-26.06

Asona Ltd. Office & Factory
6 Mahunga Drive, Māngere
Bridge, Auckland 2022
New Zealand
NZBN: 9429036035175

New Zealand

T: +64(0)9 525 6575

E: info@asona.co.nz

W: www.asona.co.nz

Australia

T: 1 800 240361

E: info@asona.com.au

W: www.asona.com.au

asona

triton pool panel vg™

High Sound Absorbing Ceiling Panel for Swimming Pools

5.0 Cutting

EB2 Cut edge band to length:

- Measure the cut length of panel and cut a length of Sonatex edge band to suit. Allow 20mm extra to be trimmed later.

N.B Sonatex™ edge banding is supplied in 1230 x 60 mm strips to allow for trimming on site. For long cuts butt join edging on site. Long lengths available to order, MOQ 40 pcs, consult Asona.



EB3 Applying the adhesive:

- Ensure the acoustic core is free from loose dust.
- Spray contact adhesive to the exposed acoustic core and back of the Sonatex edge banding taking care not to over spray onto the decorative side. Use low tack masking tape if required.
- Make a double pass to ensure sufficient adhesive coverage to ensure a strong bond.
- Allow time for the adhesive to tack off (usually, no longer than 2 minutes).

N.B Check adhesive manufacture directions before applying adhesive.



EB4 Bonding the edge band:

- Bond the Sonatex edge band to the acoustic core. Take care to control the edge as it is applied to ensure it covers the core.
- Apply hand pressure for a positive bond.



ISO 9001:2015 Registered Firm No. NZ1014

© 2026 Copyright ASONA Ltd Asona, Triton, Pool Panel VG, are trade marks of Asona Ltd,

*All dimensions are nominal. We reserve the right to change specifications. Ref. Pool Panel VG IM-26.06

Asona Ltd. Office & Factory
6 Mahunga Drive, Māngere
Bridge, Auckland 2022
New Zealand
NZBN: 9429036035175

New Zealand

T: +64(0)9 525 6575

E: info@asona.co.nz

W: www.asona.co.nz

Australia

T: 1 800 240361

E: info@asona.com.au

W: www.asona.com.au

asona

triton pool panel vg™

High Sound Absorbing Ceiling Panel for Swimming Pools

5.0 Cutting

EB5 Trim and sand the edge:

Carefully trim away the excess Sonatex edge band using the sharp utility knife.

Good knife control is required to avoid cutting into the face, use a flat edge as a guide if required.

Use a medium to fine (180- 220 grit) sanding block paper to buff and tidy the edge.

N.B Do not over sand as this can expose the acoustic core.



EB6 QA:

Turn the panel over and inspect the facing and the edge. Carefully remove any over spray and clean up any finger marks by buffing the panel with a piece of Sonatex or 'magic sponge' cleaner.

The Triton Pool Panel VG is now ready for installation.



ISO 9001:2015 Registered Firm No. NZ1014

© 2026 Copyright ASONA Ltd Asona, Triton, Pool Panel VG, are trade marks of Asona Ltd,

*All dimensions are nominal. We reserve the right to change specifications. Ref. Pool Panel VG IM-26.06

Asona Ltd. Office & Factory
6 Mahunga Drive, Māngere
Bridge, Auckland 2022
New Zealand
NZBN: 9429036035175

New Zealand

T: +64(0)9 525 6575

E: info@asona.co.nz

W: www.asona.co.nz

Australia

T: 1 800 240361

E: info@asona.com.au

W: www.asona.com.au

asona

triton pool panel vg™

High Sound Absorbing Ceiling Panel for Swimming Pools

6.0 Tools

Box Cutter, Knife, Utility Knife.	
Tape Measure	
Tee Square	
Fine Tooth Hole Saw (10 tpi bi metal)	
Sliding drop saw with dust extraction and fine tooth saw blade	 
90° Power Drill	

ISO 9001:2015 Registered Firm No. NZ1014

© 2026 Copyright ASONA Ltd Asona, Triton, Pool Panel VG, are trade marks of Asona Ltd,

*All dimensions are nominal. We reserve the right to change specifications. Ref. Pool Panel VG IM-26.06

Asona Ltd. Office & Factory
6 Mahunga Drive, Māngere
Bridge, Auckland 2022
New Zealand
NZBN: 9429036035175

New Zealand

T: +64(0)9 525 6575

E: info@asona.co.nz

W: www.asona.co.nz

Australia

T: 1 800 240361

E: info@asona.com.au

W: www.asona.com.au

asona

triton pool panel vg™

High Sound Absorbing Ceiling Panel for Swimming Pools

6.0 Tools

Fine/medium sanding block



Scraper



Soft nose spatula or putty knife for creasing



CANTAC HSE-TAC Aerosol Contact Adhesive 575ml – or equal



Clean white gloves
Eye protection
Dust mask



ISO 9001:2015 Registered Firm No. NZ1014

© 2026 Copyright ASONA Ltd Asona, Triton, Pool Panel VG, are trade marks of Asona Ltd,

*All dimensions are nominal. We reserve the right to change specifications.
Ref. Pool Panel VG IM-26.06

Asona Ltd. Office & Factory
6 Mahunga Drive, Māngere
Bridge, Auckland 2022
New Zealand
NZBN: 9429036035175

New Zealand

T: +64(0)9 525 6575

E: info@asona.co.nz

W: www.asona.co.nz

Australia

T: 1 800 240361

E: info@asona.com.au

W: www.asona.com.au

asona