

triton pool panel™

2026



High Sound Absorbing Ceiling Panel for Swimming Pools Technical Installation Manual



triton pool panel™

High Sound Absorbing Ceiling Panel for Swimming Pools Technical Installation Manual

Triton Pool Panel™ is a proprietary high sound absorbing acoustic panel designed specifically for swimming pool ceilings and high-up wall applications. The panels have an acoustic core with a concealed aluminum frame and are faced and edge wrapped in Sonatex™ glass mat composite finish which has been treated with a water repellent coating. The panels are also back laminated with a METPET foil vapour barrier.

Section	Description	Page
1.0	General information	3
2.0	Technical Installation Specifications	4
3.0	Components and Ancillary Products	5-6
4.0	Installation	7
4.1	Installation – standard, direct fixed	7-9
4.2	Installation– alternative, suspended sub-frame	10-16
4.3	Installation of services and penetrations	17
4.4	Access panels	17
4.5	Cutting	17
5.0	Tools	18
6.0	Construction details	19-21

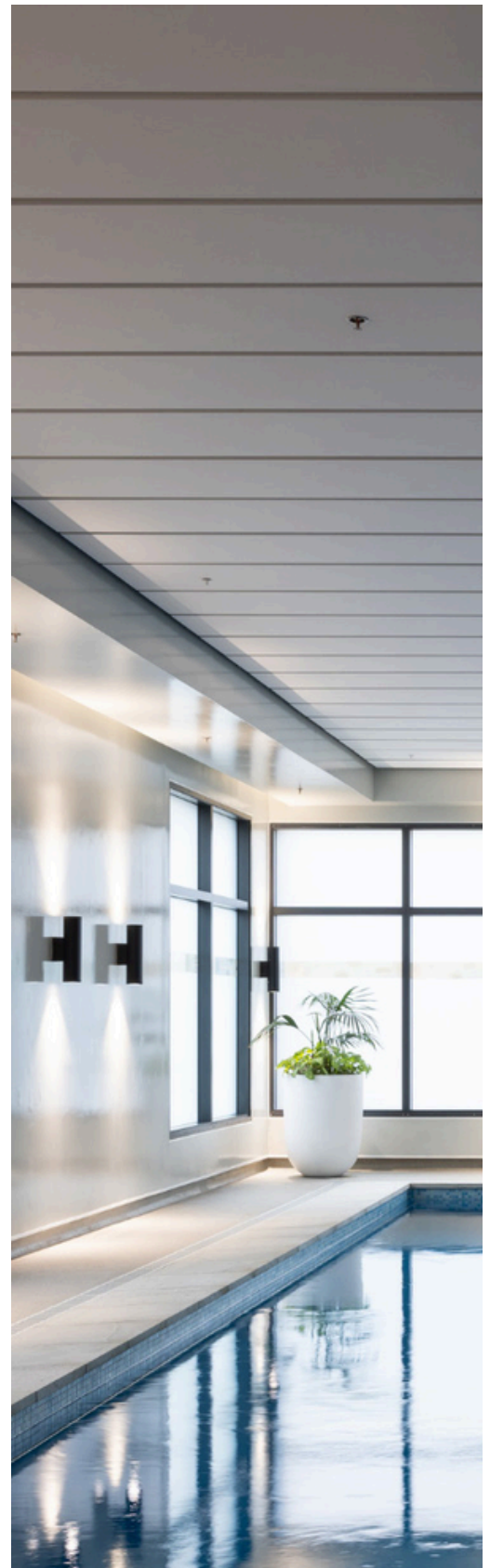

ISO 9001:2015 Registered Firm No. NZ1014

© 2026 Copyright ASONA Ltd Asona, Triton, Pool panel, are trade marks of Asona Ltd,

*All dimensions are nominal. We reserve the right to change specifications.
Ref. Pool Panel IM-26.06

Asona Ltd. Office & Factory
6 Mahunga Drive, Māngere
Bridge, Auckland 2022
New Zealand
NZBN: 9429036035175

New Zealand

T: +64(0)9 525 6575

E: info@asona.co.nz

W: www.asona.co.nz

Australia

T: 1 800 240361

E: info@asona.com.au

W: www.asona.com.au

asona

triton pool panel™

High Sound Absorbing Ceiling Panel for Swimming Pools

1.0 General Information

Description

Triton Pool™ panels are a proprietary edge wrapped 50mm acoustical panel system designed to control unwanted noise reverberation with ceilings and high level walls for indoor swimming pools.

Application

Triton Pool™ panels are to be mounted under insulated warm roof systems as an open system with no concealed or enclosed cavity behind the panels (minimum 50mm) for buildings with managed ventilation. The intent is to allow free movement of conditioned air to circulate around the panels which will help to reduce the risk of condensation. Install panels outside of the splash zone, free of direct contact with water.

Composition

Manufactured in NZ, from non-combustible glass fibre core, back laminated with METPET foil vapour barrier, framed with concealed aluminium channel and faced and edge wrapped in 2 ply Sonatex™ glass mat laminate with water repellent coating.

General

The installation details and information contained within this Asona Triton Pool Panel Installation Manual provides an extensive range of construction methods that can be adapted to suit individual projects. Asona Ltd can also provide custom made components should there be a particular requirement.

Corrosion Resistance

- Asona Ltd has selected and evaluated products that are suitable for use in a swimming pool environment as well as develop methods of construction that are used with the Triton Pool Panel system to reduce risk of corrosion.
- Selection of metal fixing and framing components is important in indoor pool environments. Galvanic corrosion and stress fracture failure of parts has occurred overseas, and care shall be taken during installation. Aluminium and Stainless Steel may be used products in indoor swimming pool environments however joining of stainless steel to aluminium is to be avoided where possible as this type of connection may lead to galvanic corrosion and failure of the fixing.
- The use of appropriate grade stainless steel fasteners are permitted and are detailed in the components schedule however isolating the stainless-steel fastener from aluminium brackets by using plastic or rubber washers is critical to prevent galvanisation occurring causing corrosion of the components. (Refer Subframe Construction Details).
- All aluminium brackets and components shall be protected against galvanic corrosion. This can be achieved by either powder coating or anodising (Marine Grade 25 micron minimum) each component. A selection of colours of both powder coating and anodising can be provided. Typically, black is the standard colour for visible components as these are camouflaged in the shadowline between panels.

Disclaimer

“Swimming pool environments require materials and components to have a high resistance to corrosion. The materials and components detailed within this guide provide a high resistance to the corrosive effects of an indoor swimming pool environment.”

“Asona Triton Pool Panels and components as described must be used and installed in accordance with the installation instructions detailed within this guide. Use of any other installation methods, materials or components may result in component failure and void the warranty of the product and system”.



ISO 9001:2015 Registered Firm No. NZ1014

© 2026 Copyright ASONA Ltd Asona, Triton, Pool panel, are trade marks of Asona Ltd,

*All dimensions are nominal. We reserve the right to change specifications. Ref. Pool Panel IM-26.06

Asona Ltd. Office & Factory New Zealand Australia
6 Mahunga Drive, Māngere T: +64(0)9 525 6575 T: 1 800 240361
Bridge, Auckland 2022 E: info@asona.co.nz E: info@asona.com.au
New Zealand W: www.asona.co.nz W: www.asona.com.au
NZBN: 9429036035175

asona

triton pool panel™

High Sound Absorbing Ceiling Panel for Swimming Pools

2.0 Technical Installation Specification

Back loading:

Max. 1.5 kg/m², point loads shall be independently supported.

Humidity:

Max 95% R/H at 45°C. Face not designed for direct contact with water. Control humidity to prevent condensation.

NZ Building Code:

Clause B2—durability, 5 years.

Maintenance:

Clean with vacuum, soft brush, or damp cloth. Re-surfacing of soiled panels available, consult Asona.

Thermal Resistance:

R 1.47 m²C/W

Weight:

3 kg/m²

Handling & Storage

- Handle with care, avoid bending and edge damage.
- Store Triton Pool Panels on a flat dry surface with adequate support to prevent bending.
- Keep dry, clean, and free from dust and debris.
- Pay special attention to the edges.
- When handling wear white gloves to avoid marking the panels.
- When storing onsite protect the panels from possible damage by other trades.

Limitations of Use

- The Triton Pool Panel is not designed for use in external applications.
- Face is not designed for direct contact with water.
- Maximum humidity/temperature 95% R/H at 45°C. It is recommended to control humidity to 70% RH maximum to prevent condensation forming.
- Back loading — Panels are not to be used by sub-trades to support other services or equipment. No overlay loads, M&E services and point loads to be independently supported. Lightweight fittings may be attached, ref Section 4.3.

Installation

- The installation of Asona Triton Pool Panels can be carried out by competent tradesperson or suspended ceiling installer who has received training from Asona.

Health & Safety and PPE

- Wear loose long sleeve clothing.
- Safety glasses.
- Clean gloves.
- Dust mask.
- If cutting with power tools use dust extraction.

Seismic Bracing

- Triton Pool panels are designed to be attached to the building structure, purlins, beams or battens with solid aluminium Z brackets. Bracing is generally not required.
- If the panels are attached to a suspended sub structure or a lined suspended ceiling system, then the weight of the Triton Pool panels shall be included in the seismic design calculations. Install bracing as required by the seismic design. Bracing shall be of a material type suitable for pool environments.
- For preliminary advice, please contact Asona Ltd.

Do's

- Use the specified components as detailed in this manual.
- Maintain a minimum 50mm gap between and behind panels to maintain free air movement around panels.
- Control the indoor environment to prevent condensation occurring on any building element through use of mechanical ventilation. It is recommended to control humidity to 70% RH maximum to prevent condensation forming.
- Avoid penetrations of the Pool Panel wherever possible by installing utilities between panels. Adjust panel sizes to accommodate services. Where this is not possible, penetrations through the panels must have sufficient clearance around the penetration.

Don'ts

- Do not install Asona Triton Pool Panels until the building is water tight.
- Do not use galvanized fasteners in a Swimming Pool environment.
- Do not combine different metals together such as Aluminium and Stainless Steel unless they are isolated from each other. Failure to isolate may result in galvanic corrosion.
- Do not install panels within the splash zone or in direct contact with water, or areas subject to, but not limited to, condensation, leaking pipes and/or ducts or steam.

ISO 9001:2015 Registered Firm No. NZ1014

© 2026 Copyright ASONA Ltd Asona, Triton, Pool panel, are trade marks of Asona Ltd,

*All dimensions are nominal. We reserve the right to change specifications. Ref. Pool Panel IM-26.06

Asona Ltd. Office & Factory New Zealand Australia
6 Mahunga Drive, Māngere T: +64(0)9 525 6575 T: 1 800 240361
Bridge, Auckland 2022 E: info@asona.co.nz E: info@asona.com.au
New Zealand W: www.asona.co.nz W: www.asona.com.au
NZBN: 9429036035175

asona

triton pool panel™

High Sound Absorbing Ceiling Panel for Swimming Pools

3.0 Components & Ancillary Products

Pool Panel

(Back view of panel shown showing foil and folded edges)

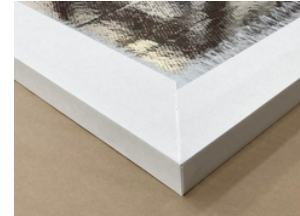

Standard Z Fixing Bracket - 50mm

To prevent galvanic corrosion, aluminium brackets are powder coated or anodised to Marine Grade 25 micron minimum

Custom Size Brackets are available, please contact Asona

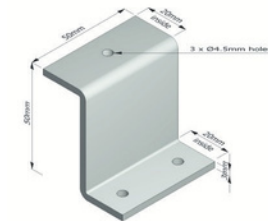

Rivets

Ø4.0mm x 10-13mm dome head Aluminium Pop Rivets



Screws - fixing to timber

4 x 40 mm countersunk 1.4529 grade Stainless Steel Screw



Screws - fixing to steel

Consult with design engineer

Suspended subframe

Aluminium T Section 50 x 50 x 3.0mm
Powder coated or anodised Marine Grade 25 micron minimum



Suspended subframe

Aluminium Angle Section 30 x 30 x 3.0mm
Powder coated or anodised Marine Grade 25 micron minimum

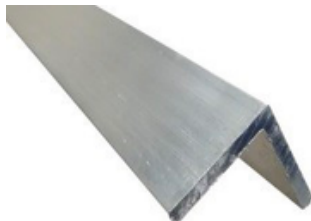

ISO 9001:2015 Registered Firm No. NZ1014

© 2026 Copyright ASONA Ltd Asona, Triton, Pool panel, are trade marks of Asona Ltd,

*All dimensions are nominal. We reserve the right to change specifications.
Ref. Pool Panel IM-26.06

Asona Ltd. Office & Factory
6 Mahunga Drive, Māngere
Bridge, Auckland 2022
New Zealand
NZBN: 9429036035175

New Zealand

T: +64(0)9 525 6575

E: info@asona.co.nz

W: www.asona.co.nz

Australia

T: 1 800 240361

E: info@asona.com.au

W: www.asona.com.au

asona

triton pool panel™

High Sound Absorbing Ceiling Panel for Swimming Pools

3.0 Components & Ancillary Products, cont.

Cup Isolating Washer

Use to isolate stainless steel countersunk head timber screw
Isolating Cup Washer item (Item # FIX-Hi-Q 03-SWS0905)



Flat Isolating Washer

Used to isolate counter sunk stainless steel fixing screws from the aluminium Z bracket.
M5 x 19 x 2.4mm (Item # FIX-Hi-Q 03-PNW5/19B)



Concrete Anchor - 30 x 30 x 3 mm angle to concrete fixing

M6 x 40mm 316 Stainless steel concrete anchor



Additional Bracket Options — L Fixing Brackets

Aluminium powder coated or anodised Marine Grade 25 micron minimum. 30, 50, 85, 100mm sizes.

Custom Size Brackets are available, please contact Asona

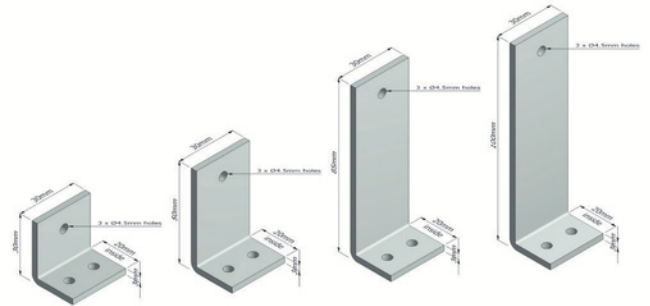

Additional Bracket Options — Flat Tabbed Bracket

Aluminium powder coated or anodised Marine Grade 25 micron minimum

Note, flat brackets shall only be used in custom fixing applications where a Z or L bracket cannot be used. A minimum 50 mm air flow gap must be maintained.

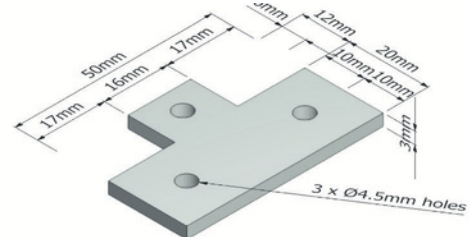

End Cap C Channel

0.9 x 15 x 50 x 15 mm aluminium C channel, powder coated white.
Designed to cap open ends of site cut panels.

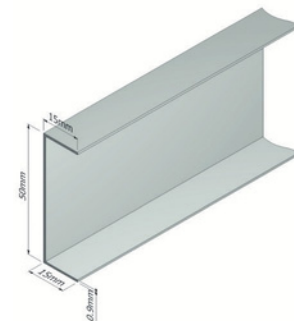

ISO 9001:2015 Registered Firm No. NZ1014

© 2026 Copyright ASONA Ltd Asona, Triton, Pool panel, are trade marks of Asona Ltd,

*All dimensions are nominal. We reserve the right to change specifications.
Ref. Pool Panel IM-26.06

Asona Ltd. Office & Factory
6 Mahunga Drive, Māngere
Bridge, Auckland 2022
New Zealand
NZBN: 9429036035175

New Zealand

T: +64(0)9 525 6575

E: info@asona.co.nz

W: www.asona.co.nz

Australia

T: 1 800 240361

E: info@asona.com.au

W: www.asona.com.au

asona

triton pool panel™

High Sound Absorbing Ceiling Panel for Swimming Pools

4.0 Installation

4.1 Standard Method

The preferred installation method is to mount Triton Pool Panels with Z brackets to treated timber battens (by others) that are fixed to the building structure (eg portal beams, purlins).

Direct Fixed Installation of Asona Triton Pool Panels to Existing Building Framework or Substrate

Installation shall not commence until the building is watertight and dry.

Installation Overview:

Set out panel panels to ensure a minimum gap of 50mm is achieved between all edges of the panels. Use a laser or string lines to keep lines plumb and square and to create panel anchor locations on the structure/substrate that match the location of the brackets on the panels. Timber battens may be parallel or perpendicular to the long side of the panel to suit building structure.

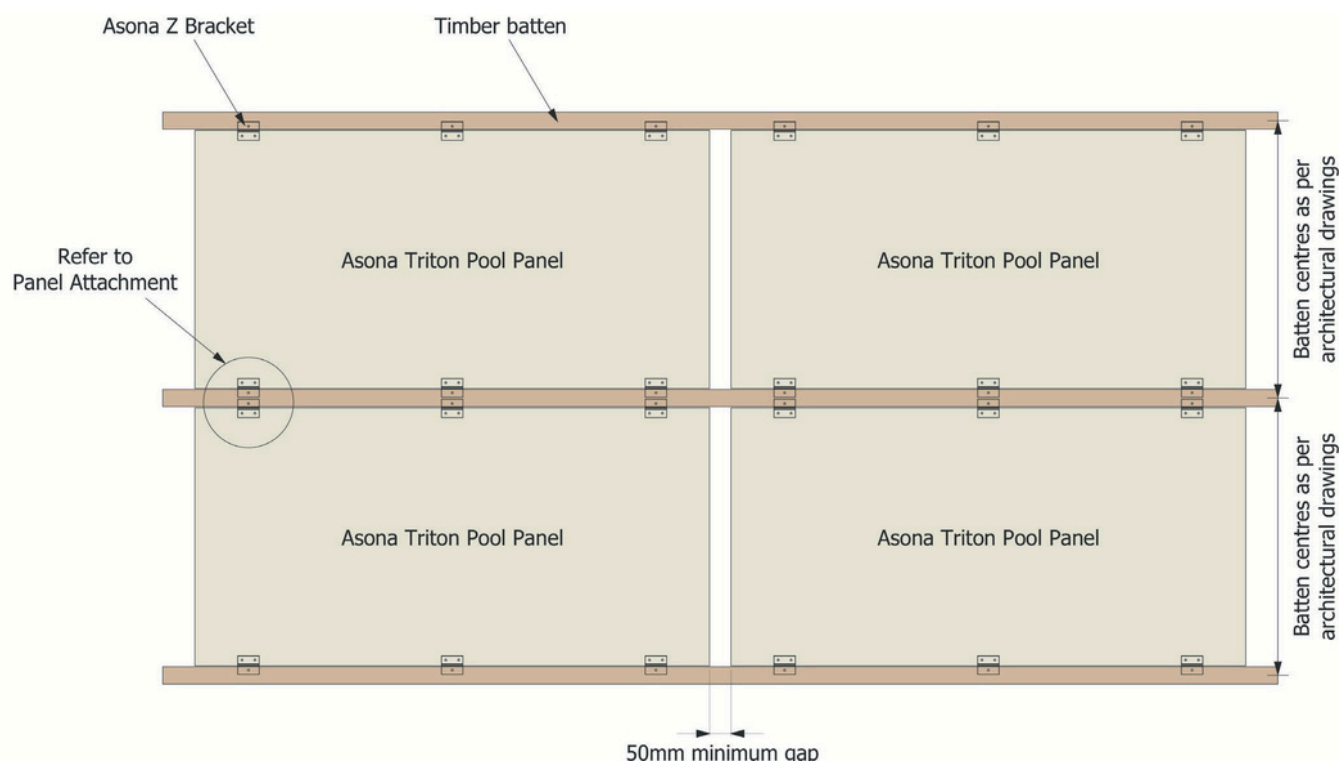

ISO 9001:2015 Registered Firm No. NZ1014

© 2026 Copyright ASONA Ltd Asona, Triton, Pool panel, are trade marks of Asona Ltd,

*All dimensions are nominal. We reserve the right to change specifications. Ref. Pool Panel IM-26.06

Asona Ltd. Office & Factory
6 Mahunga Drive, Māngere
Bridge, Auckland 2022
New Zealand
NZBN: 9429036035175

New Zealand

T: +64(0)9 525 6575

E: info@asona.co.nz

W: www.asona.co.nz

Australia

T: 1 800 240361

E: info@asona.com.au

W: www.asona.com.au

asona

triton pool panel™

High Sound Absorbing Ceiling Panel for Swimming Pools

4.0 Installation

Bracket Positioning:

Panels may be supported at sides or ends as determined by sub structure above.

Side support

A minimum of 4 brackets per panel shall be used on panel lengths 300 – 2400 mm.

For panels 2410 – 3000 mm, 6 brackets shall be used.

Ensure the Pool Panel is laid flat on a clean dry surface when attaching brackets.

- Position and install brackets 100 to 150mm from the corner of the panel.
- Position a bracket centrally on panels greater than 2400mm long.

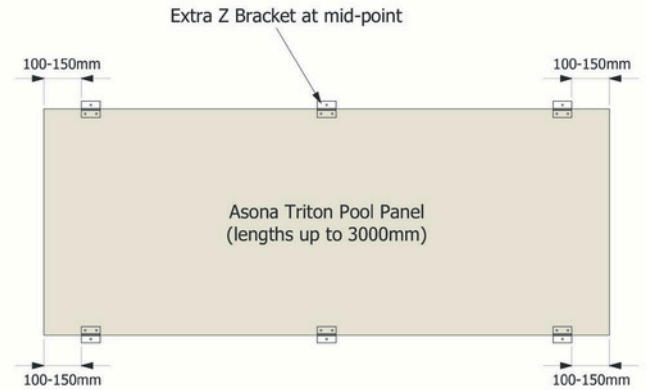

End support option

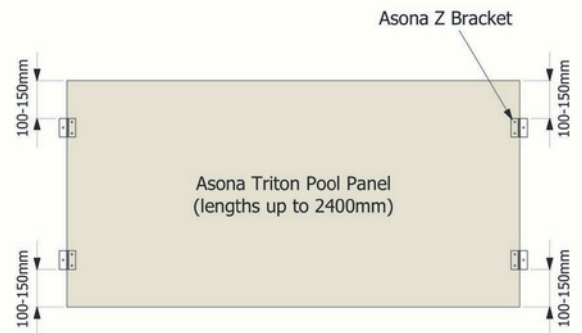

Bracket Attachment:

Determine the required height and allow for the depth of the direct fix bracket and panel thickness. Typically 100 mm.

Drill and rivet the aluminium Z bracket (or other) to the rear concealed metal frame using 2 x Ø 4.0mm aluminium rivets per bracket.

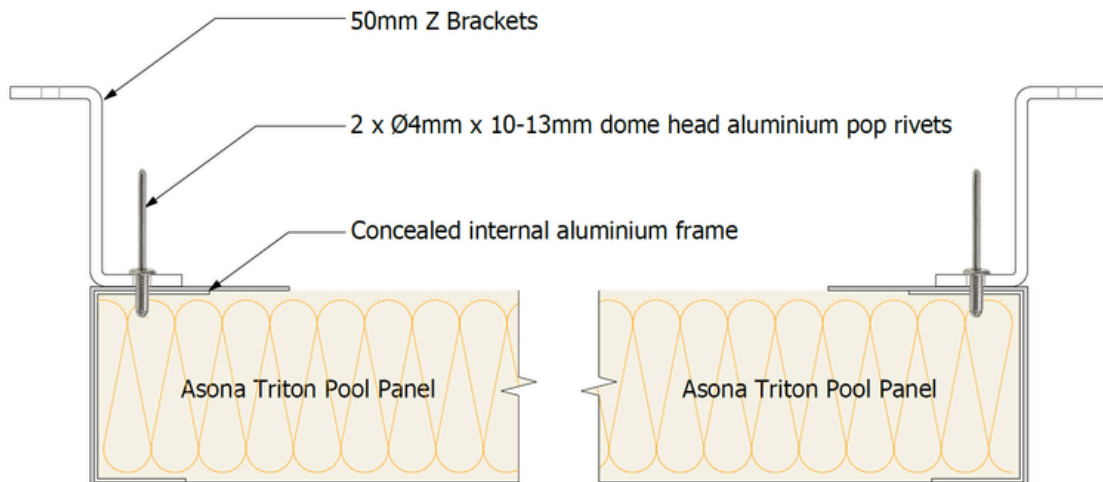

ISO 9001:2015 Registered Firm No. NZ1014

© 2026 Copyright ASONA Ltd Asona, Triton, Pool panel, are trade marks of Asona Ltd,

*All dimensions are nominal. We reserve the right to change specifications. Ref. Pool Panel IM-26.06

Asona Ltd. Office & Factory
6 Mahunga Drive, Māngere
Bridge, Auckland 2022
New Zealand
NZBN: 9429036035175

New Zealand

T: +64(0)9 525 6575

E: info@asona.co.nz

W: www.asona.co.nz

Australia

T: 1 800 240361

E: info@asona.com.au

W: www.asona.com.au

asona

triton pool panel™

High Sound Absorbing Ceiling Panel for Swimming Pools

4.0 Installation

Note: Wear white cotton gloves to prevent soiling of the Pool Panel finish.

Panel Installation

Lift the Pool Panels into position using 2 people or a panel lifter to support the panel. Fix off to the existing substrate using the appropriate corrosion resistant fasteners suitable for the material type (timber, aluminium, steel, or concrete).

Refer to components schedule.



Panel Attachment:

When installing Pool Panels to timber framing use 40 mm 1.4529 grade Stainless Steel Screw with nylon isolation washer.

Directly fix the Pool Panels to the timber substrate ensuring the nylon washer is between the screw head and the "Z" Brackets".

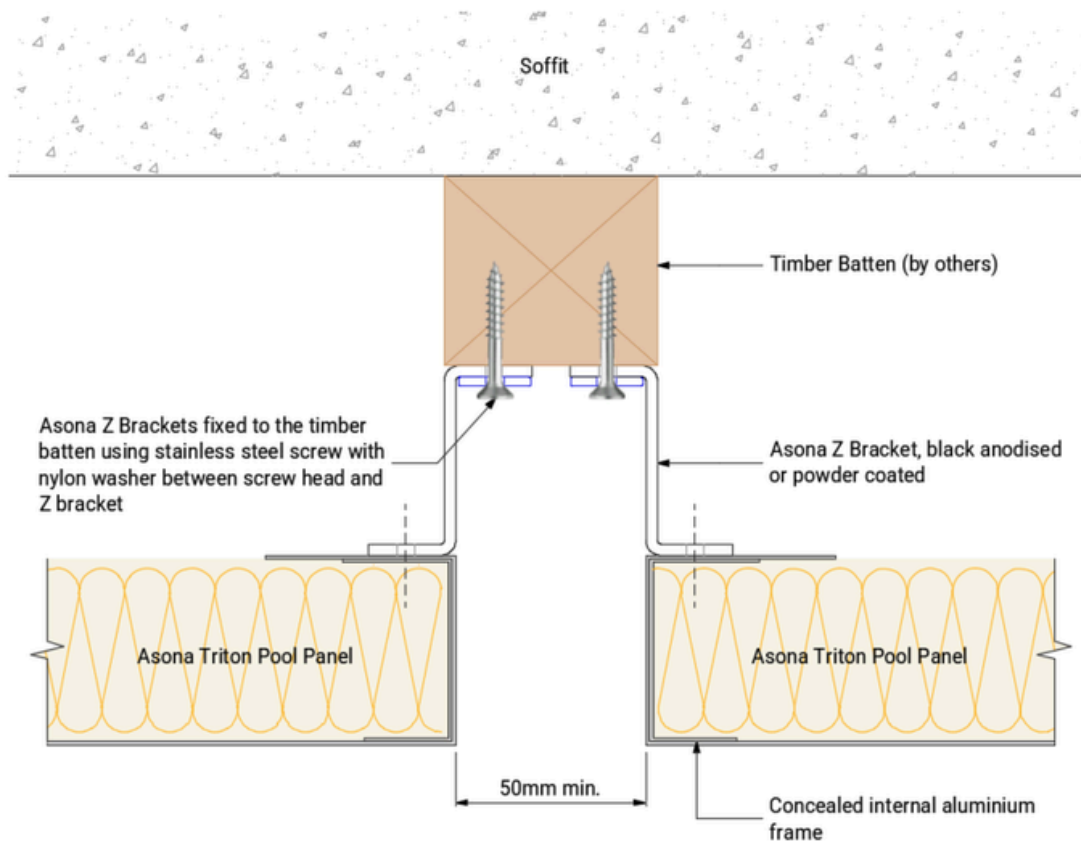

ISO 9001:2015 Registered Firm No. NZ1014

© 2026 Copyright ASONA Ltd Asona, Triton, Pool panel, are trade marks of Asona Ltd,

*All dimensions are nominal. We reserve the right to change specifications. Ref. Pool Panel IM-26.06

Asona Ltd. Office & Factory
6 Mahunga Drive, Māngere
Bridge, Auckland 2022
New Zealand
NZBN: 9429036035175

New Zealand

T: +64(0)9 525 6575

E: info@asona.co.nz

W: www.asona.co.nz

Australia

T: 1 800 240361

E: info@asona.com.au

W: www.asona.com.au

asona

triton pool panel™

High Sound Absorbing Ceiling Panel for Swimming Pools

4.0 Installation

4.2 Installing Asona Triton Pool Panels to a Suspended Aluminium Subframe

Installation shall not commence until the building is watertight and dry.

Installation Overview:

Where the installation of a subframe is required, set out the subframe to suit the panel layout, ensuring that the panel brackets coincide with the subframe. Sub frame may be parallel or perpendicular to the long side of the panel to suit building structure.

The subframe may be installed using aluminium T and L angle sections at centres to suit the Asona Triton Pool Panel sizes, including any seismic bracing requirements.

Attach Z brackets to the back of the Triton Pool Panel at designated points using 2 x Ø4mm aluminium rivets per bracket.

Lift and position the Triton Pool panel and attach to the subframe with the 4mm aluminium rivets.

Ensure spacing between panels is no less than 50 mm to allow for air movement.

Panels up to 3000mm long

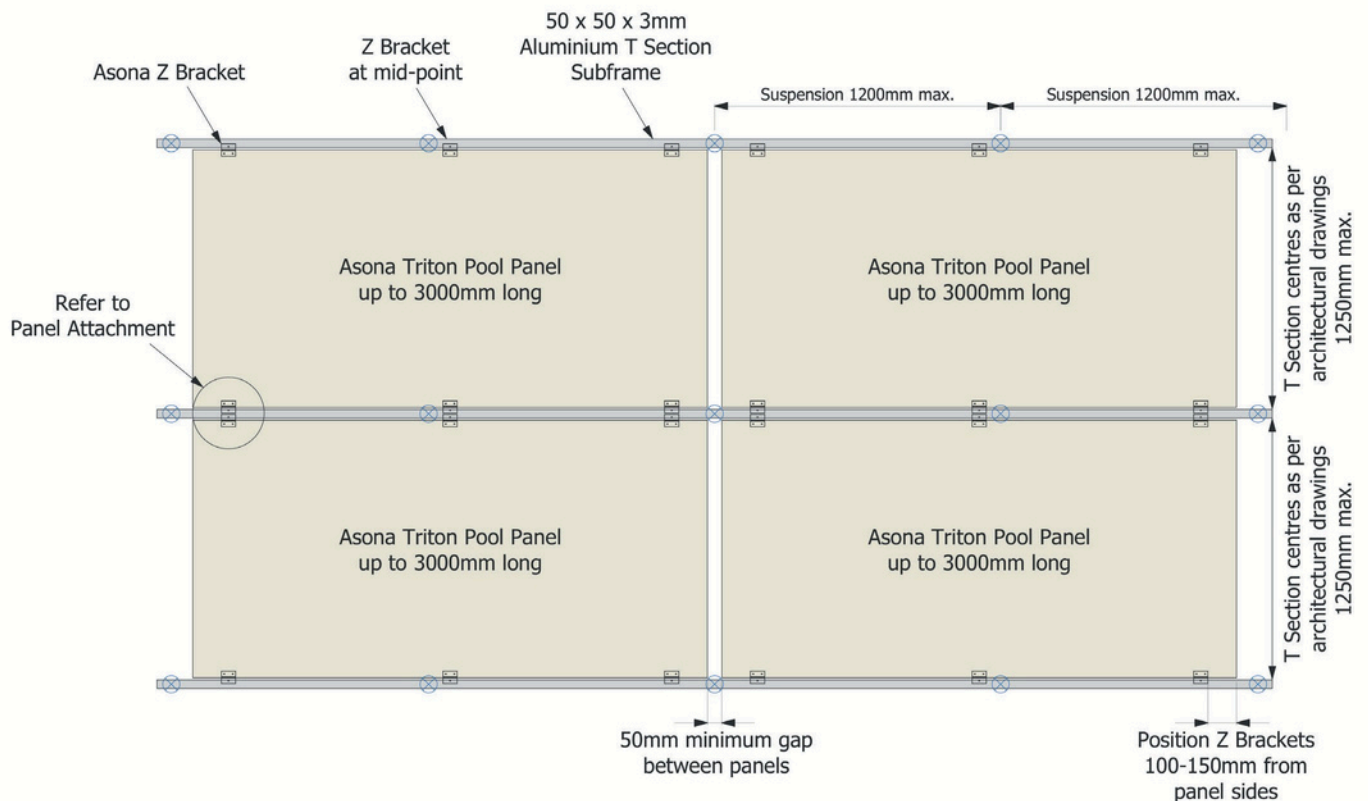

ISO 9001:2015 Registered Firm No. NZ1014

© 2026 Copyright ASONA Ltd Asona, Triton, Pool panel, are trade marks of Asona Ltd,

*All dimensions are nominal. We reserve the right to change specifications. Ref. Pool Panel IM-26.06

Asona Ltd. Office & Factory
6 Mahunga Drive, Māngere
Bridge, Auckland 2022
New Zealand
NZBN: 9429036035175

New Zealand

T: +64(0)9 525 6575

E: info@asona.co.nz

W: www.asona.co.nz

Australia

T: 1 800 240361

E: info@asona.com.au

W: www.asona.com.au

asona

triton pool panel™

High Sound Absorbing Ceiling Panel for Swimming Pools

4.0 Installation

Installing Asona Triton Pool Panels to a Suspended Aluminium Subframe—cont.

Subframe Construction Detail:

Construct a suspended subframe using powder coated or Marine Grade anodised 30 x 30 x 3.0mm Aluminium hangers and 50 x 50 x 3.0mm Aluminium T section. Ensure the layout of the suspended subframe coincides with the brackets of the Asona Triton Pool Panel.

Determine the required height to allow for the thickness of the panel plus Z bracket depth eg 50mm Pool Panel + 50mm Z bracket =100mm above specified FCL height.

Install solid L angle hangers at 1200mm centres maximum along the length of the 50 x 50 x 3.0mm Aluminium T section subframe.

To a Concrete Structure:

When fixing to the underside of concrete attach the aluminium angle using a M6 x 40mm 316 Stainless steel concrete anchor. Use a strip of DPC between the aluminium angle and concrete structure. Ensure the insulating washer is between the head of the concrete anchor and the aluminium angle.

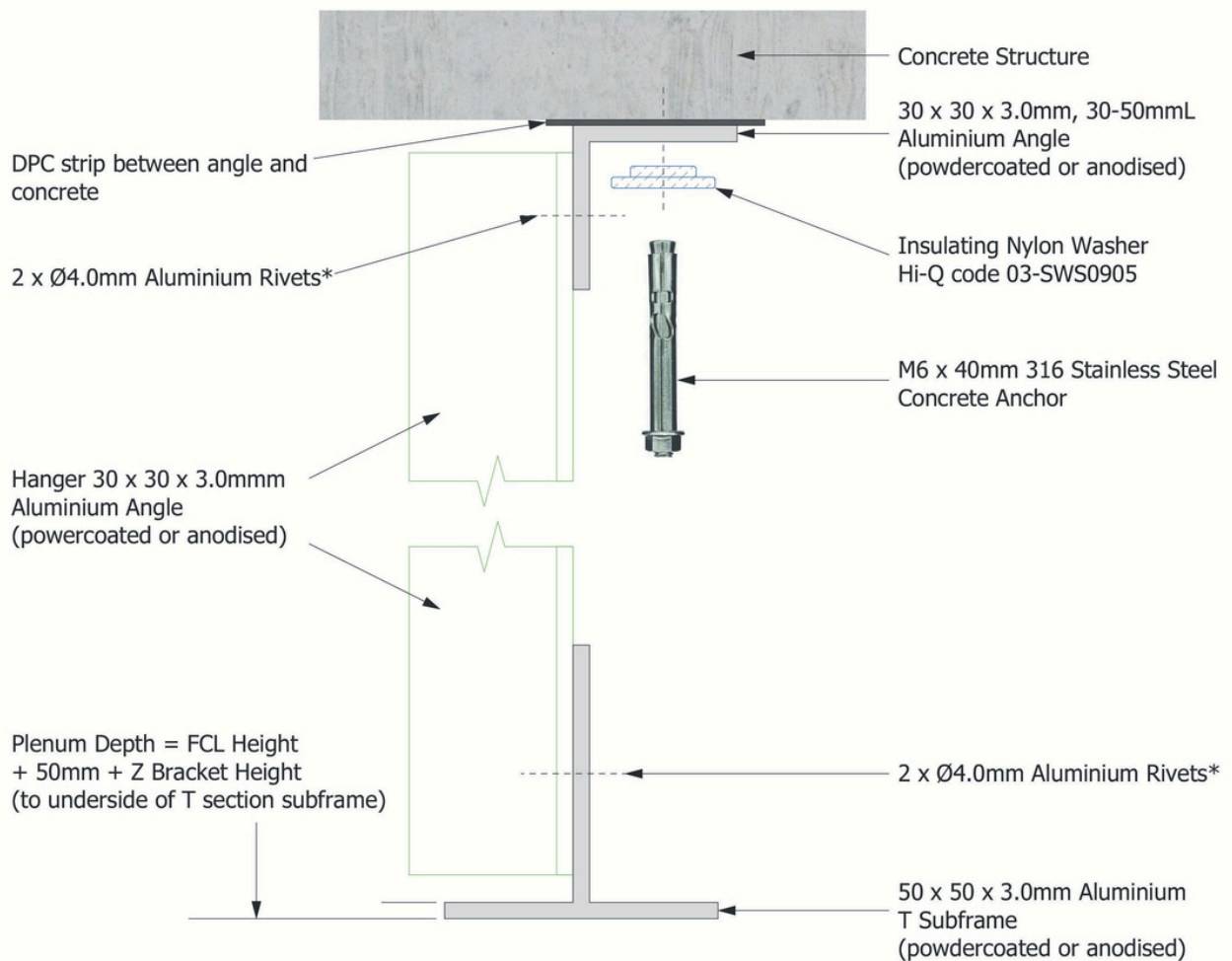

*Refer Section 3, Components for full rivet specification

ISO 9001:2015 Registered Firm No. NZ1014

© 2026 Copyright ASONA Ltd Asona, Triton, Pool panel, are trade marks of Asona Ltd,

*All dimensions are nominal. We reserve the right to change specifications. Ref. Pool Panel IM-26.06

Asona Ltd. Office & Factory
6 Mahunga Drive, Māngere
Bridge, Auckland 2022
New Zealand
NZBN: 9429036035175

New Zealand

T: +64(0)9 525 6575

E: info@asona.co.nz

W: www.asona.co.nz

Australia

T: 1 800 240361

E: info@asona.com.au

W: www.asona.com.au

asona

triton pool panel™

High Sound Absorbing Ceiling Panel for Swimming Pools

4.0 Installation

Installing Asona Triton Pool Panels to a Suspended Aluminium Subframe—cont.

Subframe Construction Detail:

Construct a suspended subframe using powder coated or Marine Grade anodised 30 x 30 x 3.0mm Aluminium hangers and 50 x 50 x 3.0mm Aluminium T section. Ensure the layout of the suspended subframe coincides with the brackets of the Asona Triton Pool Panel.

Determine the required height to allow for the thickness of the panel plus Z bracket depth eg 50mm Pool Panel + 50mm Z bracket =100mm above specified FCL height.

Install solid L angle hangers at 1200mm centres maximum along the length of the 50 x 50 x 3.0mm Aluminium T section subframe.

To a Timber Structure:

When fixing to the underside of timber attach the aluminium angle using 40 mm 1.4529 grade Stainless Steel Screw with nylon washers. Ensure the nylon washer is between the head of the screw and the aluminium angle.

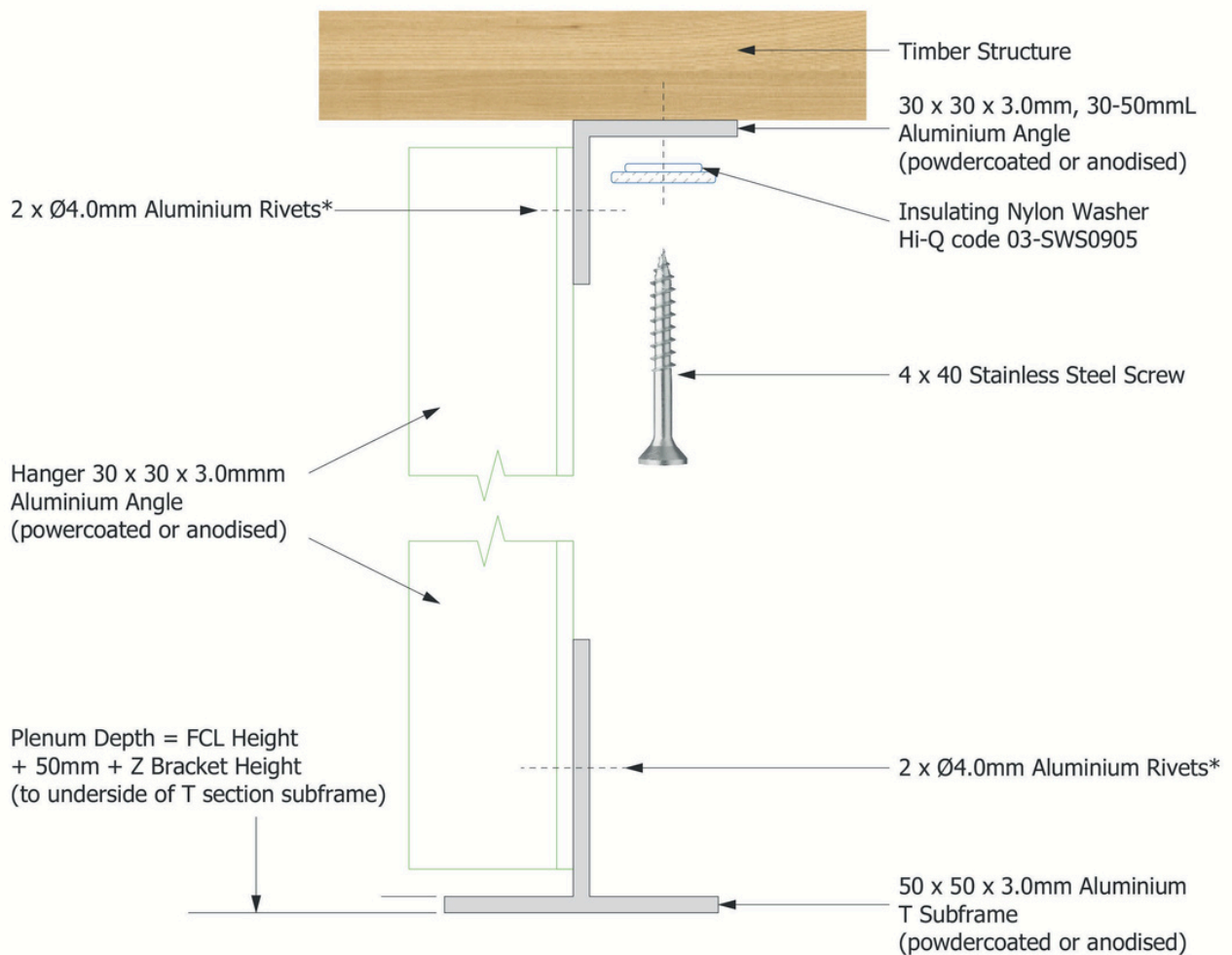

*Refer Section 3, Components for full rivet specification

ISO 9001:2015 Registered Firm No. NZ1014

© 2026 Copyright ASONA Ltd Asona, Triton, Pool panel, are trade marks of Asona Ltd,

*All dimensions are nominal. We reserve the right to change specifications. Ref. Pool Panel IM-26.06

Asona Ltd. Office & Factory
6 Mahunga Drive, Māngere
Bridge, Auckland 2022
New Zealand
NZBN: 9429036035175

New Zealand

T: +64(0)9 525 6575

E: info@asona.co.nz

W: www.asona.co.nz

Australia

T: 1 800 240361

E: info@asona.com.au

W: www.asona.com.au

asona

triton pool panel™

High Sound Absorbing Ceiling Panel for Swimming Pools

4.0 Installation

Installing Asona Triton Pool Panels to a Suspended Aluminium Subframe—cont.

Subframe Construction Detail:

Construct a suspended subframe using powder coated or Marine Grade anodised 30 x 30 x 3.0mm Aluminium hangers and 50 x 50 x 3.0mm Aluminium T section. Ensure the layout of the suspended subframe coincides with the brackets of the Asona Triton Pool Panel.

Determine the required height to allow for the thickness of the panel plus Z bracket depth eg 50mm Pool Panel + 50mm Z bracket =100mm above specified FCL height.

Install solid L angle hangers at 1200mm centres maximum along the length of the 50 x 50 x 3.0mm Aluminium T section subframe.

To a Steel Structure:

When fixing to the underside of a Steel Purlin or primary steel structure, attach the aluminium angle using 2 x Ø4.0mm Aluminium Rivets. Ensure the insulating washer is between the steel and the aluminium angle. Coat exposed rivet with corrosion resistant paint.

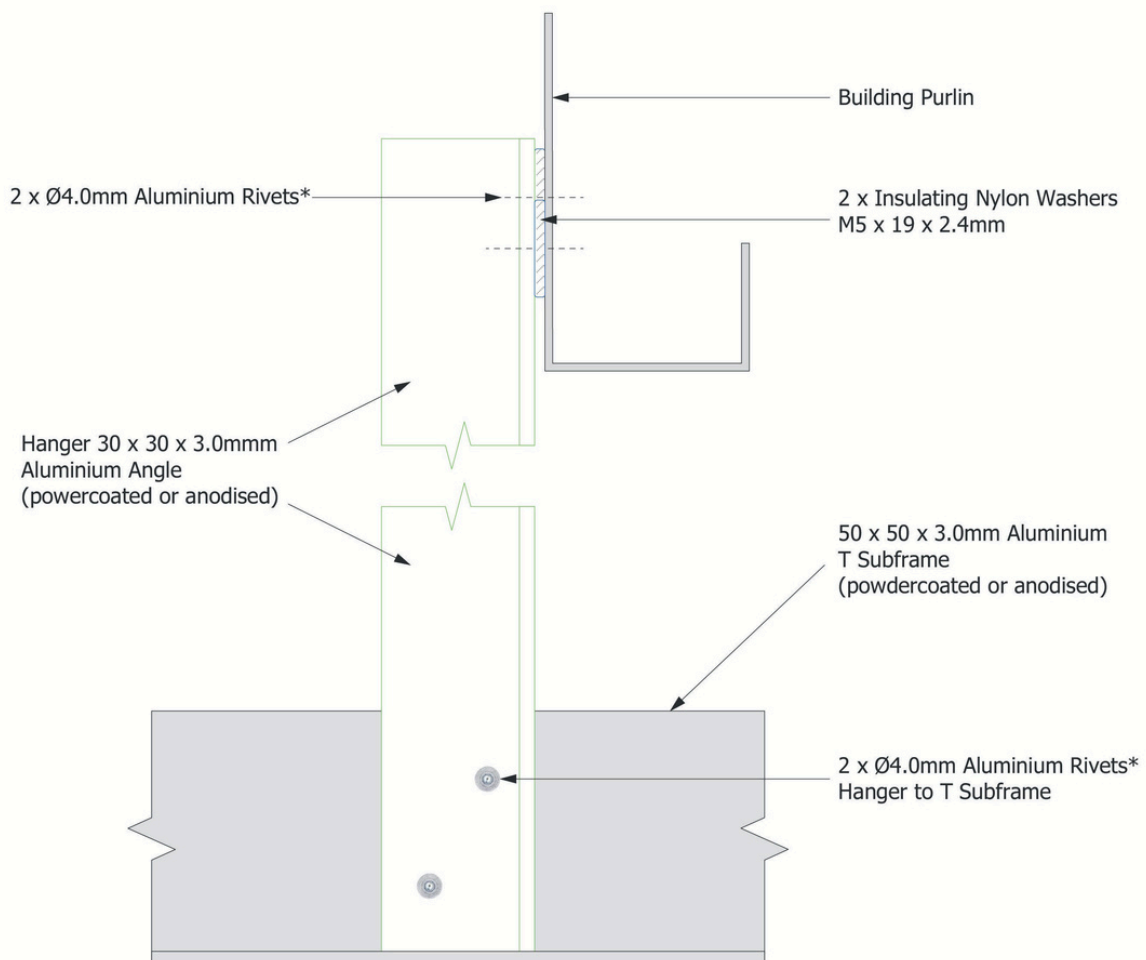

*Refer Section 3, Components for full rivet specification

ISO 9001:2015 Registered Firm No. NZ1014

© 2026 Copyright ASONA Ltd Asona, Triton, Pool panel, are trade marks of Asona Ltd,

*All dimensions are nominal. We reserve the right to change specifications. Ref. Pool Panel IM-26.06

Asona Ltd. Office & Factory
6 Mahunga Drive, Māngere
Bridge, Auckland 2022
New Zealand
NZBN: 9429036035175

New Zealand

T: +64(0)9 525 6575

E: info@asona.co.nz

W: www.asona.co.nz

Australia

T: 1 800 240361

E: info@asona.com.au

W: www.asona.com.au

asona

triton pool panel™

High Sound Absorbing Ceiling Panel for Swimming Pools

4.0 Installation

Installing Asona Triton Pool Panels to a Suspended Aluminium Subframe—cont.

Subframe Construction Detail:

Construct a suspended subframe using powder coated or Marine Grade anodised 30 x 30 x 3.0mm Aluminium hangers and 50 x 50 x 3.0mm Aluminium T section. Ensure the layout of the suspended subframe coincides with the brackets of the Asona Triton Pool Panel.

Determine the required height to allow for the thickness of the panel plus Z bracket depth eg 50mm Pool Panel + 50mm Z bracket =100mm above specified FCL height.

Install solid L angle hangers at 1200mm centres maximum along the length of the 50 x 50 x 3.0mm Aluminium T section subframe.

To a Sheet Lined Suspended Ceiling:

When fixing to the underside of a suspended ceiling with sheet lining, attach the aluminium angle bracket through the lining into the ceiling frame using 1.4529 grade Stainless Steel Screw suitable for light gauge steel (up to 0.75 BMT), with a nylon washer. Ensure the nylon washer is between the head of the screw and the aluminium angle.

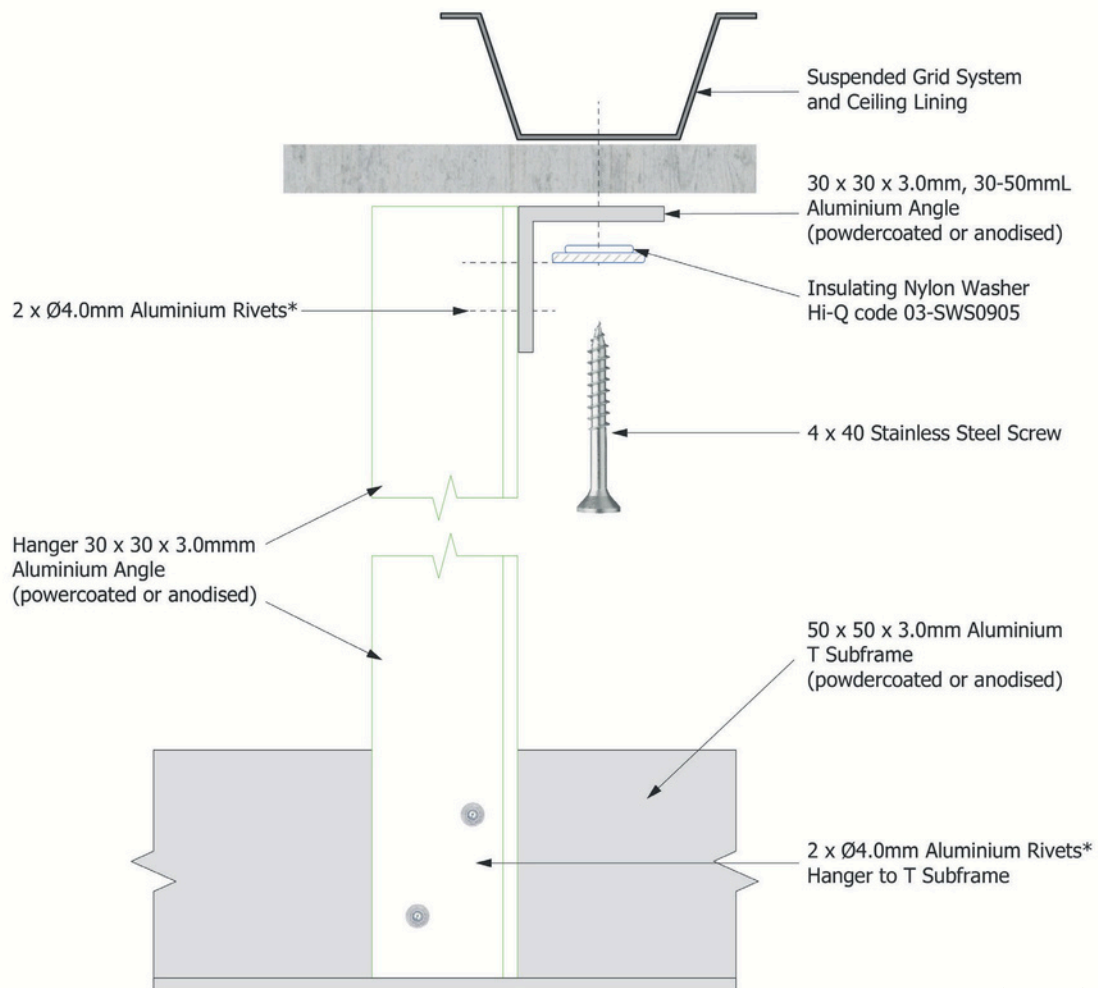

*Refer Section 3, Components for full rivet specification

ISO 9001:2015 Registered Firm No. NZ1014

© 2026 Copyright ASONA Ltd Asona, Triton, Pool panel, are trade marks of Asona Ltd,

*All dimensions are nominal. We reserve the right to change specifications. Ref. Pool Panel IM-26.06

Asona Ltd. Office & Factory
6 Mahunga Drive, Māngere
Bridge, Auckland 2022
New Zealand
NZBN: 9429036035175

New Zealand

T: +64(0)9 525 6575

E: info@asona.co.nz

W: www.asona.co.nz

Australia

T: 1 800 240361

E: info@asona.com.au

W: www.asona.com.au

asona

triton pool panel™

High Sound Absorbing Ceiling Panel for Swimming Pools

4.0 Installation

Installing Asona Triton Pool Panels to a Suspended Aluminium Subframe—cont.

Bracket Positioning:

Panels may be supported at sides or ends as determined by sub structure above.

Side support

A minimum of 4 brackets per panel shall be used on panel lengths 300 – 2400 mm.

For panels 2410 – 3000 mm, 6 brackets shall be used.

Ensure the Pool Panel is laid flat on a clean dry surface when attaching brackets.

- Position and install brackets 100 to 150mm from the corner of the panel.
- Position a bracket centrally on panels greater than 2400mm long.

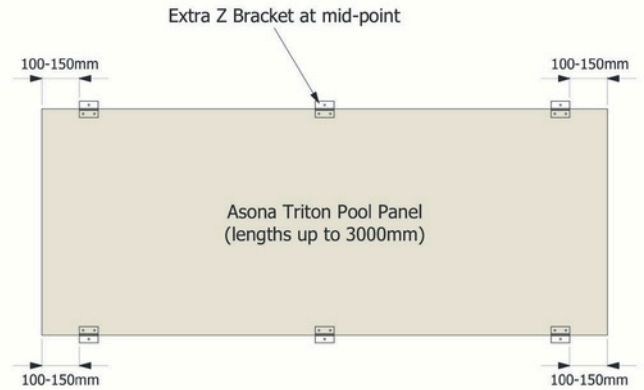

End support option

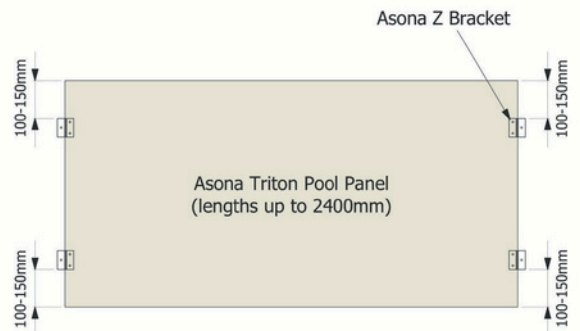

Bracket Attachment:

Determine the required height and allow for the depth of the direct fix bracket and panel thickness. Typically 100 mm.

Drill and rivet the aluminium Z bracket (or other) to the rear concealed metal frame using 2 x Ø 4.0mm aluminium rivets per bracket.

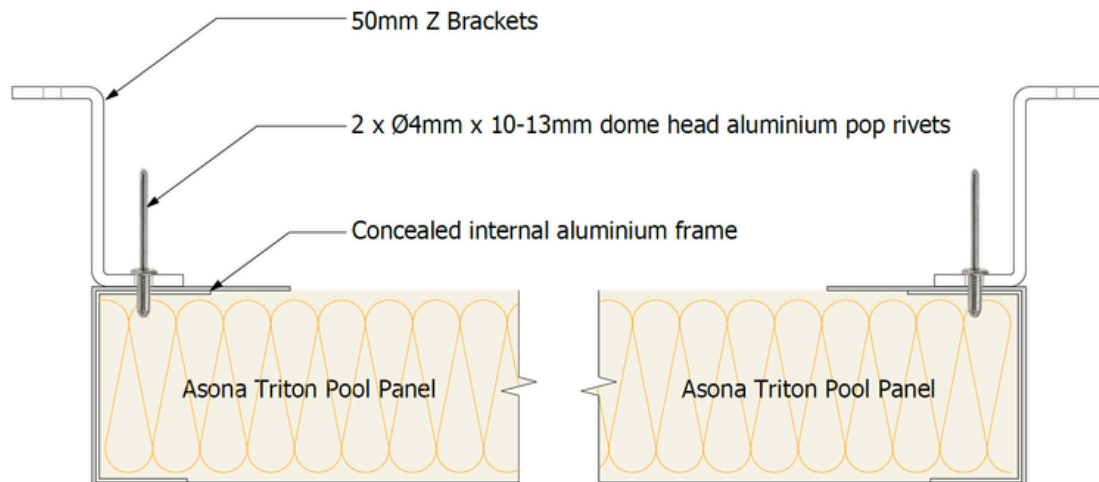

ISO 9001:2015 Registered Firm No. NZ1014

© 2026 Copyright ASONA Ltd Asona, Triton, Pool panel, are trade marks of Asona Ltd,

*All dimensions are nominal. We reserve the right to change specifications. Ref. Pool Panel IM-26.06

Asona Ltd. Office & Factory
6 Mahunga Drive, Māngere
Bridge, Auckland 2022
New Zealand
NZBN: 9429036035175

New Zealand

T: +64(0)9 525 6575

E: info@asona.co.nz

W: www.asona.co.nz

Australia

T: 1 800 240361

E: info@asona.com.au

W: www.asona.com.au

asona

triton pool panel™

High Sound Absorbing Ceiling Panel for Swimming Pools

4.0 Installation

Installing Asona Triton Pool Panels to a Suspended Aluminium Subframe—cont.

Note: Wear white cotton gloves to prevent soiling of the Pool Panel finish.

Panel Installation

Lift the Pool Panels into position using 2 people or a panel lifter to support the panel. Fix off to the subframe.



Panel Attachment:

Install the Pool Panel to the T Subframe. Fix using 1 x Ø4.0mm aluminium rivet through each of the Z Brackets

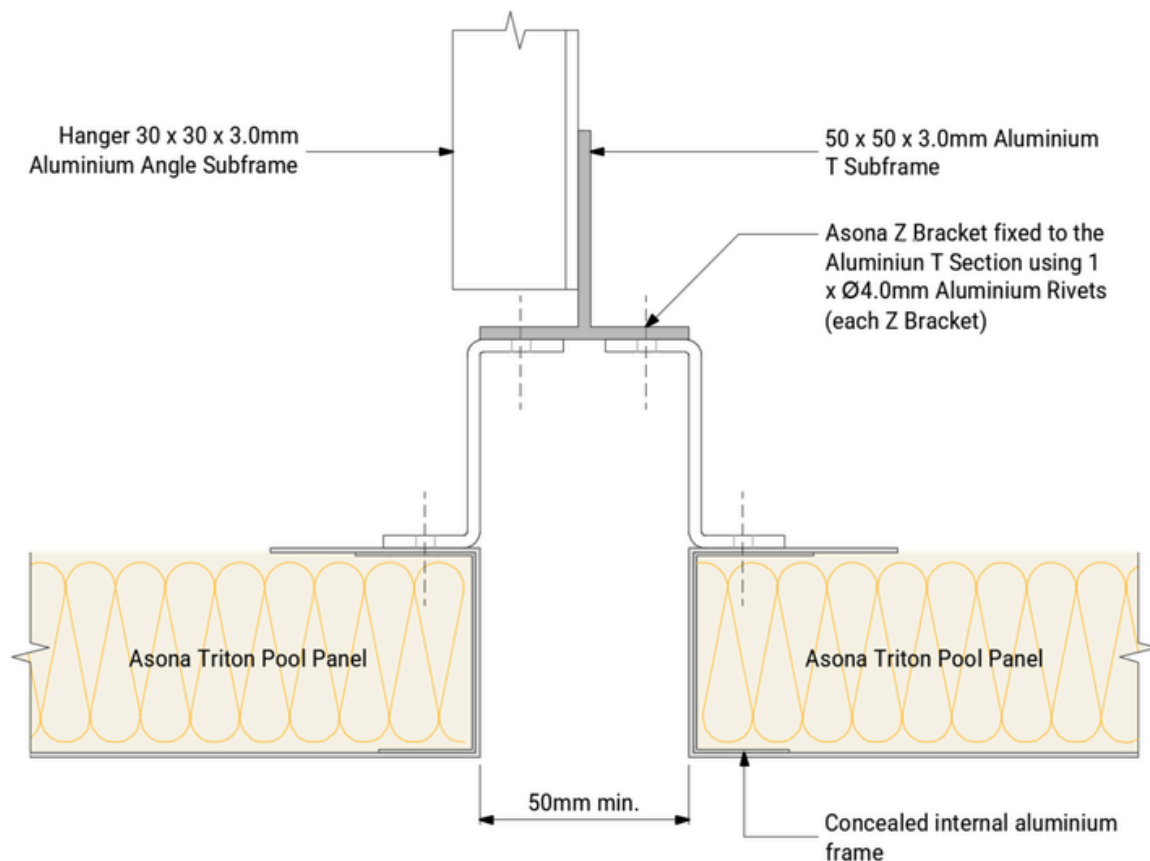

*Refer Section 3, Components for full rivet specification

ISO 9001:2015 Registered Firm No. NZ1014

© 2026 Copyright ASONA Ltd Asona, Triton, Pool panel, are trade marks of Asona Ltd,

*All dimensions are nominal. We reserve the right to change specifications. Ref. Pool Panel IM-26.06

Asona Ltd. Office & Factory
6 Mahunga Drive, Māngere
Bridge, Auckland 2022
New Zealand
NZBN: 9429036035175

New Zealand

T: +64(0)9 525 6575

E: info@asona.co.nz

W: www.asona.co.nz

Australia

T: 1 800 240361

E: info@asona.com.au

W: www.asona.com.au

asona

triton pool panel™

High Sound Absorbing Ceiling Panel for Swimming Pools

4.0 Installation

4.3 Installation of Services and Penetrations

Mechanical and electrical services and fire sprinklers shall ideally be positioned between panels and attached to the structure independent of the Triton Pool Panel. Adjust panel sizes to accommodate services.

Where this is not possible, surface mounted lightweight fittings less than 1 kg, (such as smoke detectors), point loads shall be independently supported. A common method is to place a treated timber batten across the back of the panel, edge to edge. Screw through the panel into the batten using 1.4529 grade Stainless Steel Screw.

Take care not to over tighten screws or to compress the face.

Penetrations through the panels must have sufficient clearance around the penetration that they cannot be in contact with the Triton Pool Panel.

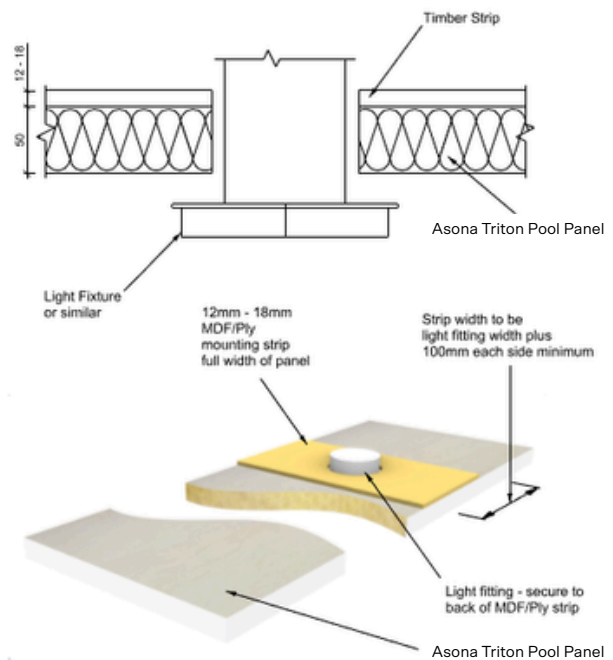
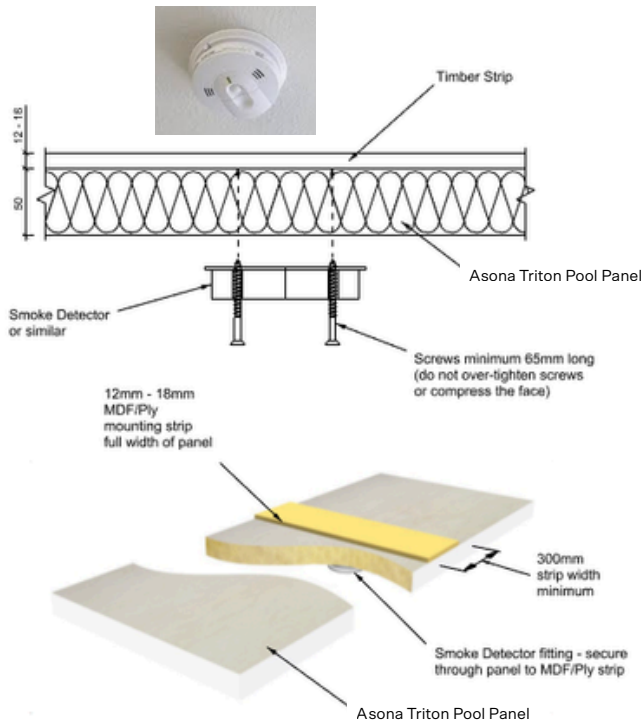

4.4 Access Panels

Access panels in Triton Pool panels shall be avoided where possible. Screw fixed panels may be demounted to gain access above. Consult Asona.

4.5 Cutting

Cutting of panels shall be avoided where possible.

Custom made to measure panels are available, consult Asona.

If cutting of panels is required to adjust for onsite dimension, then you will need to have pre-purchased C channel capping from Asona. Best cutting results are achieved when using a bench saw or plunge saw with guidance rail. Use a fine-tooth aluminium cutting blade and dust extractor. Protect the panel face with a cover sheet.

After cutting:

- Tidy cut edges and remove loose dust with a clean brush.
- Cut C channel capping to length.
- Apply construction adhesive to the inside of the C channel cap.
- Position C channel and press to ensure contact with adhesive.
- Allow time for the adhesive to set.
- 2 x white head aluminium rivets (3.2mm) fixed to the back flange may be used to provide additional fixing.

ISO 9001:2015 Registered Firm No. NZ1014

© 2026 Copyright ASONA Ltd Asona, Triton, Pool panel, are trade marks of Asona Ltd,

*All dimensions are nominal. We reserve the right to change specifications. Ref. Pool Panel IM-26.06

Asona Ltd. Office & Factory
6 Mahunga Drive, Māngere
Bridge, Auckland 2022
New Zealand
NZBN: 9429036035175

New Zealand

T: +64(0)9 525 6575

E: info@asona.co.nz

W: www.asona.co.nz

Australia

T: 1 800 240361

E: info@asona.com.au

W: www.asona.com.au

asona

triton pool panel™

High Sound Absorbing Ceiling Panel for Swimming Pools

5.0 Tools

Box Cutter, Knife, Utility Knife.



Tape Measure



Tee Square



Fine Tooth Hole Saw (10 tpi bi metal)



Sliding drop saw with dust extraction and fine tooth saw blade



90° Power Drill



ISO 9001:2015 Registered Firm No. NZ1014

© 2026 Copyright ASONA Ltd Asona, Triton, Pool panel, are trade marks of Asona Ltd,

*All dimensions are nominal. We reserve the right to change specifications. Ref. Pool Panel IM-26.06

Asona Ltd. Office & Factory
6 Mahunga Drive, Māngere
Bridge, Auckland 2022
New Zealand
NZBN: 9429036035175

New Zealand

T: +64(0)9 525 6575

E: info@asona.co.nz

W: www.asona.co.nz

Australia

T: 1 800 240361

E: info@asona.com.au

W: www.asona.com.au

asona

triton pool panel™

High Sound Absorbing Ceiling Panel for Swimming Pools

6.0 Construction Details

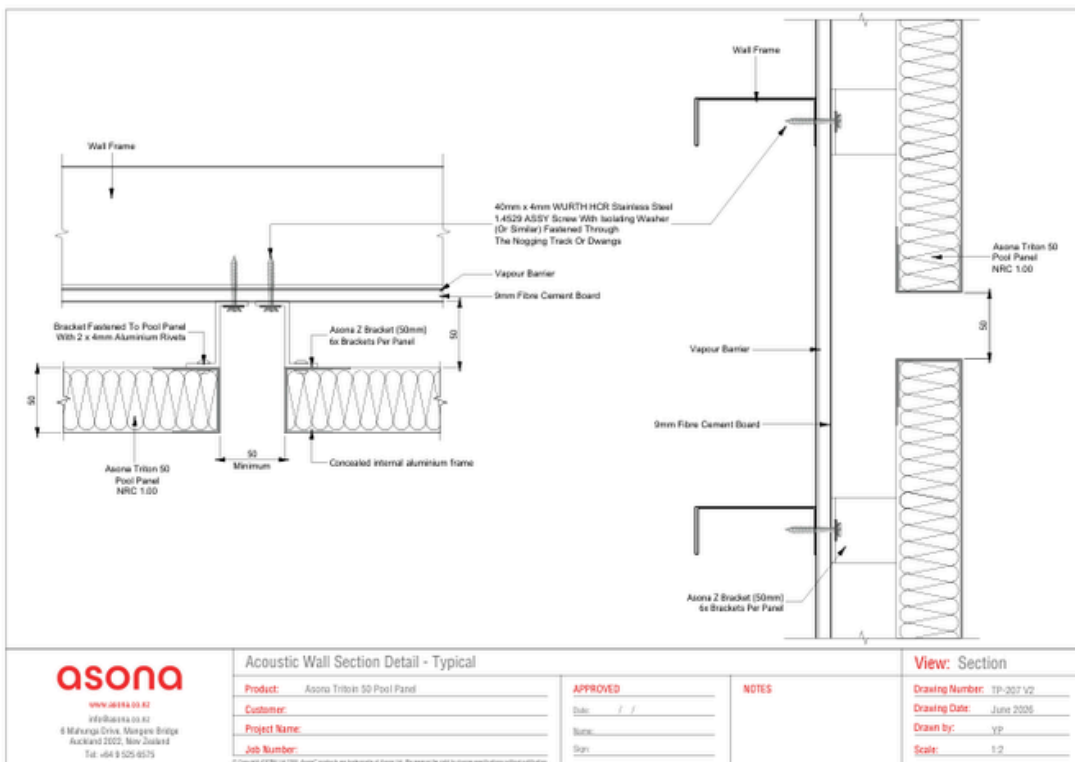
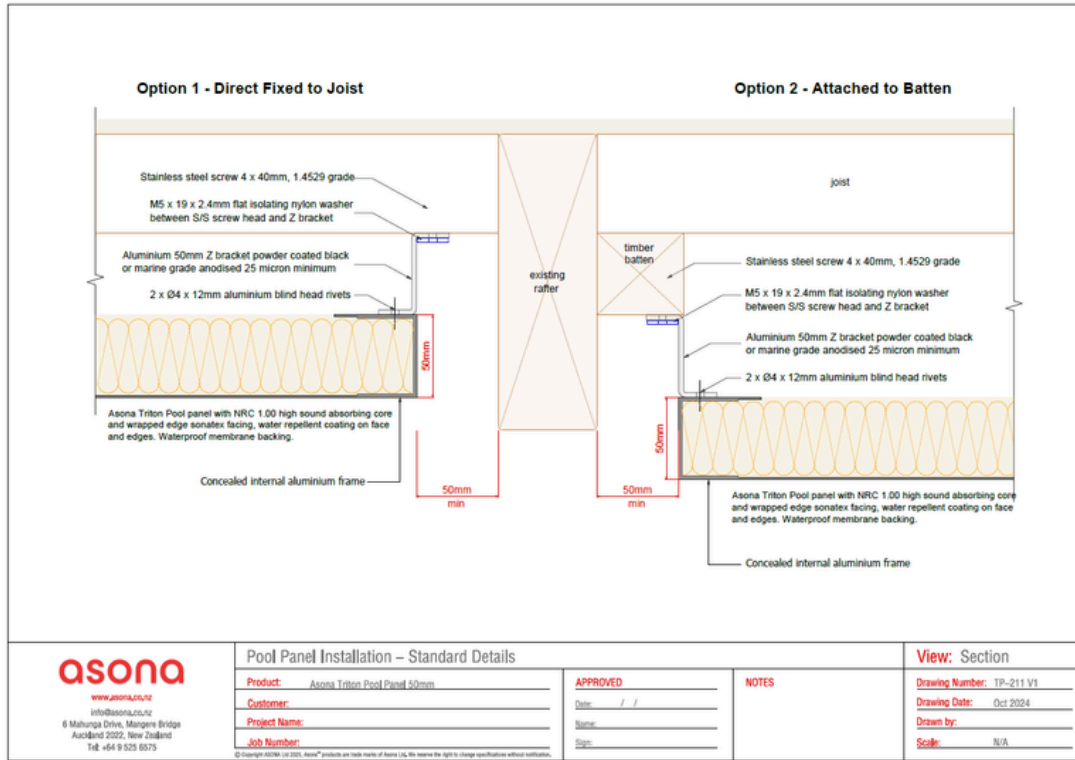

ISO 9001:2015 Registered Firm No. NZ1014

© 2026 Copyright ASONA Ltd Asona, Triton, Pool panel, are trade marks of Asona Ltd,

*All dimensions are nominal. We reserve the right to change specifications. Ref. Pool Panel IM-26.06

Asona Ltd. Office & Factory
6 Mahunga Drive, Māngere
Bridge, Auckland 2022
New Zealand
NZBN: 9429036035175

New Zealand

T: +64(0)9 525 6575

E: info@asona.co.nz

W: www.asona.co.nz

Australia

T: 1 800 240361

E: info@asona.com.au

W: www.asona.com.au

triton pool panel™

High Sound Absorbing Ceiling Panel for Swimming Pools

6.0 Construction Details—cont.

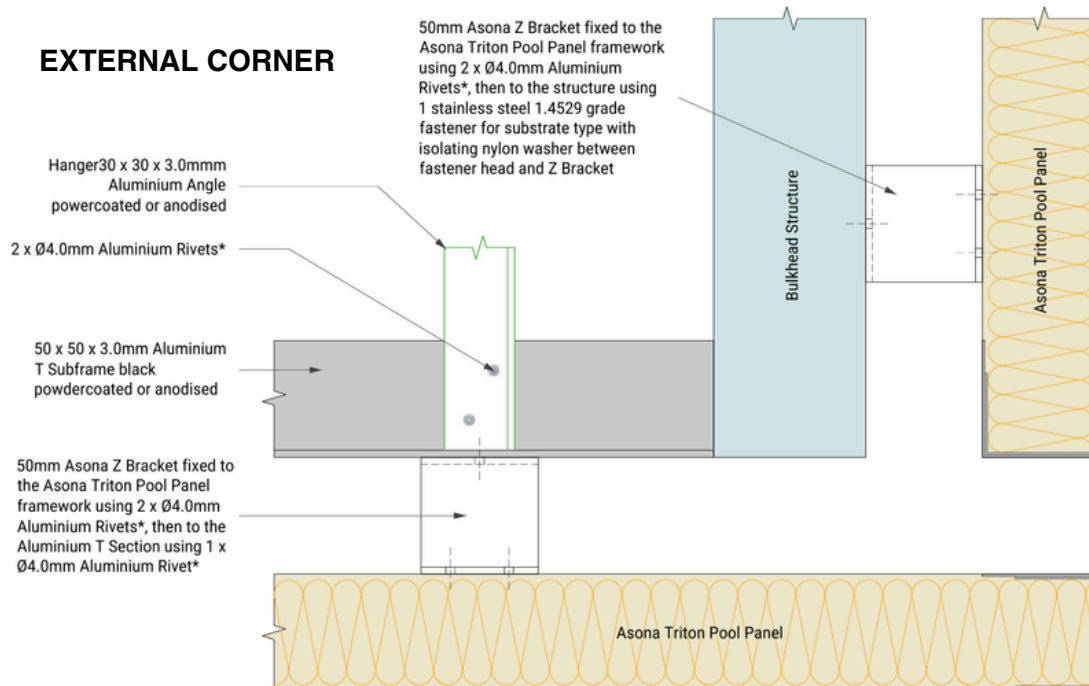
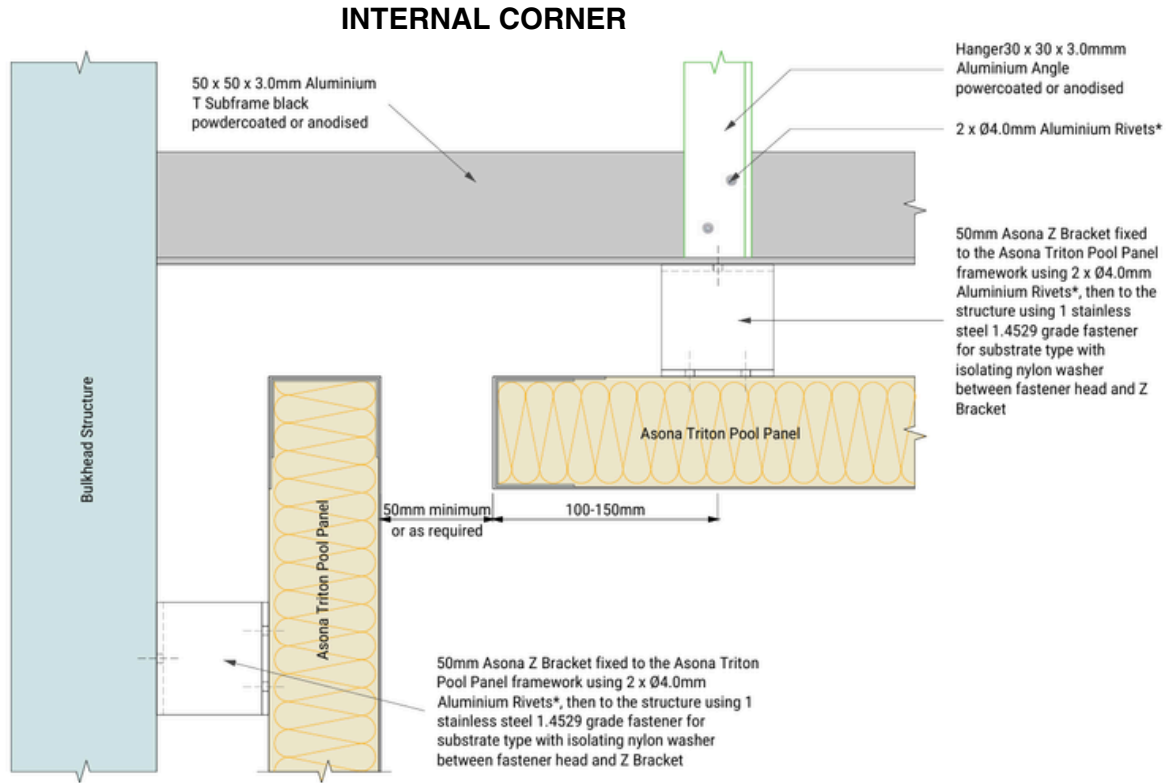

ISO 9001:2015 Registered Firm No. NZ1014

© 2026 Copyright ASONA Ltd Asona, Triton, Pool panel, are trade marks of Asona Ltd,

*All dimensions are nominal. We reserve the right to change specifications. Ref. Pool Panel IM-26.06

Asona Ltd. Office & Factory
6 Mahunga Drive, Māngere
Bridge, Auckland 2022
New Zealand
NZBN: 9429036035175

New Zealand

T: +64(0)9 525 6575

E: info@asona.co.nz

W: www.asona.co.nz

Australia

T: 1 800 240361

E: info@asona.com.au

W: www.asona.com.au

asona

triton pool panel™

High Sound Absorbing Ceiling Panel for Swimming Pools

6.0 Construction Details—cont.

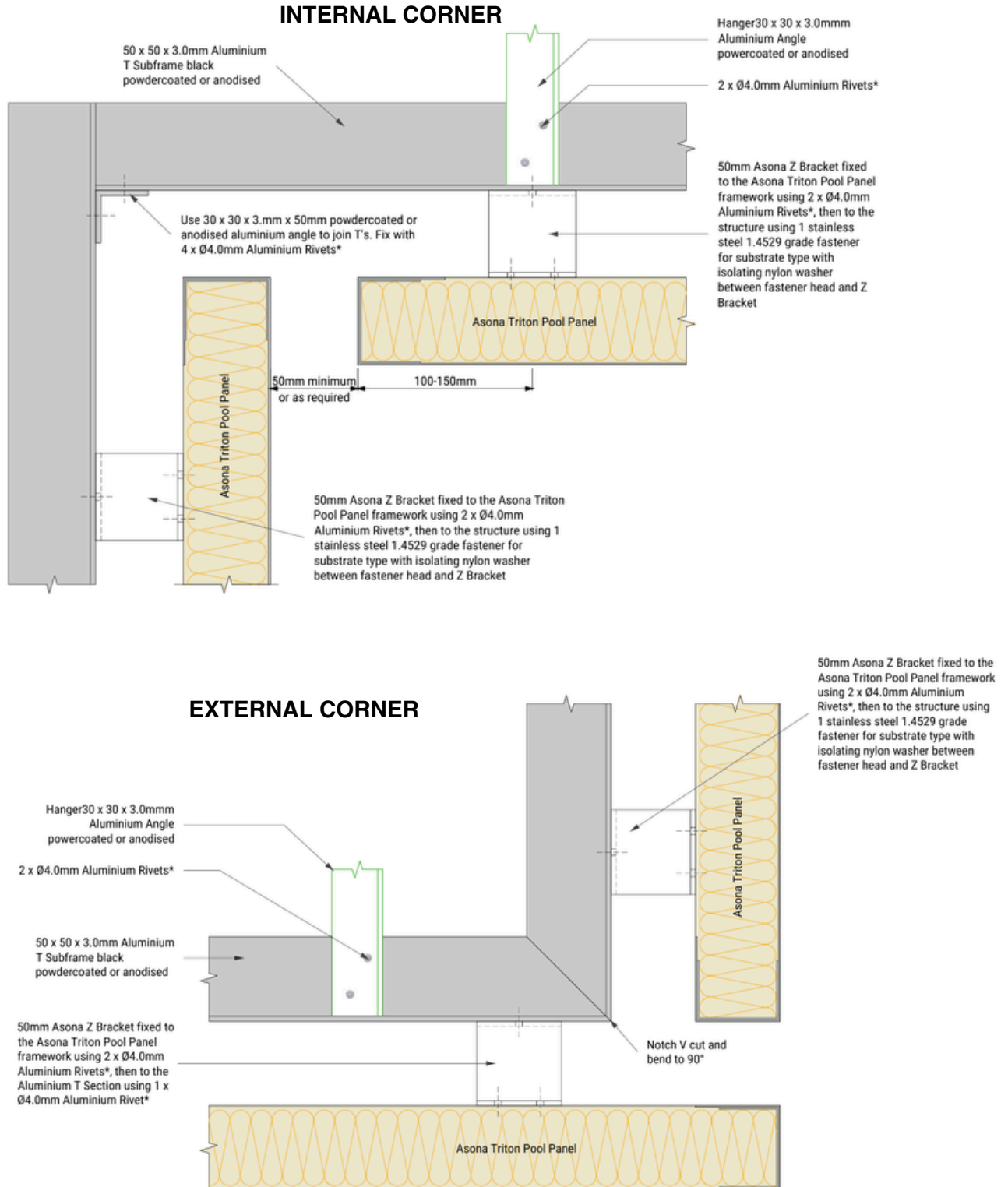

ISO 9001:2015 Registered Firm No. NZ1014

© 2026 Copyright ASONA Ltd Asona, Triton, Pool panel, are trade marks of Asona Ltd,

*All dimensions are nominal. We reserve the right to change specifications. Ref. Pool Panel IM-26.06

Asona Ltd. Office & Factory
6 Mahunga Drive, Māngere
Bridge, Auckland 2022
New Zealand
NZBN: 9429036035175

New Zealand

T: +64(0)9 525 6575

E: info@asona.co.nz

W: www.asona.co.nz

Australia

T: 1 800 240361

E: info@asona.com.au

W: www.asona.com.au

asona